

Integration of Non-synchronous Generation

Frequency Dynamics

Johan Björnstedt



LUND UNIVERSITY

Doctoral Dissertation
Department of Measurement Technology and
Industrial Electrical Engineering

2012

Department of Measurement Technology and Industrial Electrical Engineering
Faculty of Engineering
Lund University
Box 118
221 00 LUND
SWEDEN

<http://www.ica.lth.se>

ISBN: 978-91-88934-56-7
CODEN: LUTEDX/(TEIE-1064)/1-126/(2012)

© Johan Björnstedt, 2012
Printed in Sweden by Tryckeriet i E-huset, Lund University
Lund 2012

“Never forget that only dead fish swim with the stream”

Malcolm Muggeridge

Abstract

Traditionally the predominant generation has been large synchronous generators providing the system inertia. Nowadays when wind power and other non-synchronously connected units displace this synchronous generation, the system inertia is reduced. Hence higher rate of change of frequency and larger frequency deviations are expected.

This thesis deals with the impact on rate of change of frequency and frequency deviation in the Nordic power system with decreasing system inertia as well as with the introduction of synthetic inertia and frequency support from wind turbines.

Increasing wind power is a question of system inertia, governor frequency response, load frequency response and magnitude of disturbance rather than the amount of wind power in the system. As long as the system inertia is maintained at an acceptable level, the wind power production can be arbitrarily selected.

A synthetic inertia controller acting on df/dt calculated from a slight filtered frequency gives a frequency response similar to that for a synchronous generator. Further, it can damp the electromechanical oscillations between (groups of) generators in the system, provided that the turbine can handle a few periods of oscillations which are reflected in the output power. If measured frequency is filtered heavier prior to calculating df/dt the controller does not act on the oscillations. The wind turbine response is also delayed which is preferable as the hydropower reacts faster and the frequency deviation is reduced.

A frequency support controller acting on Δf is best used in combination with curtailed wind turbine output power. A predictable frequency response is obtained which can be handled similar to frequency response from traditional generation. The Δf -controller is also possible to use without curtailment but the tuning of it is very critical, especially in a system with high level of wind power. If this controller is not handled with great caution it may be devastating to the frequency dynamics.

The entire power system has to be considered to verify wind turbine behavior

in combination with already existing turbine governors. Otherwise an attempt to improve frequency dynamics can end up with worse frequency dynamics than without any control on wind power.

The amount of induction generators in the system is also likely to increase. It is shown that the synchronous and induction generator capability of delivering power to the grid during a frequency disturbance is almost solely determined by the generator and turbine mechanical system, i.e. the amount of inertia. Introducing new types of production with induction generators may affect the frequency dynamics due to a change in inertia but this is not directly related to the type of generator.

Acknowledgements

Some years ago I thought I was done with the academic world but destiny had other plans and I became a PhD-student. Now the road has come to an end, some of the insights along the way have formed this thesis while others are outside the scope of this work.

First of all I would like to express my gratitude towards my supervisors. Dr. Olof Samuelsson for the great help, guidance through the world of research and proofreading, Professor Sture Lindahl for sharing a part of his great knowledge with me, Dr. Magnus Akke for the help with the estimation algorithm in Chapter 6, Dr. Jörgen Svensson for the discussions about wind power and for proofreading this thesis.

This work has been financed by Elforsk AB. I appreciate the support from the members of the reference committee, Dr. Stefan Arnborg, Svenska Kraftnät, M.Sc. Anders Ekberg, Fortum Distribution, Dr. Jonas Persson, Vattenfall R&D, and Tech.Lic. Niklas Stråth, E.ON Elnät.

I would like to thank all the people working at the Division of Industrial Electrical Engineering and Automation. Special thanks to the friends who I have shared room with. Anna Guldbrand for helping me make decisions during the first years, Francesco Sulla for the great cooperation and for answering my questions regardless of the level of these and Ingmar Leißé for the great assistance and never ending discussions regarding various projects and problems. Further I am grateful to Dr. Per Karlsson for the guidance in the world of power electronics, Dr. Gunnar Lindstedt for the help with electronics and Getachew Darge for the cooperation in the workshop.

My parents deserve many thanks, my father for all the discussions about the mystery of electricity and my mother for patiently listening to the frequent discussions about electricity at the dinner table. Finally, thanks to my friend Ida, especially for the positive thinking...

Lund, April 2012
Johan Björnstedt

Preface

Nearly six years ago I entered the academic world as a PhD-student. At that time the project was called *Island operation of distribution systems*. About two and a half years later the licentiate thesis *Island Operation with Induction Generators, Frequency and Voltage Control* was presented. While waiting for funding for the continuation towards the PhD I was engaged in another project for almost a year. During that time the objectives of the PhD project gradually changed to finally end up with the title *Power system integration of non-synchronous generation*. This thesis is about *frequency dynamics* which was my part of the project.

Contents

CHAPTER 1 INTRODUCTION.....	1
1.1 MOTIVATION	1
1.2 OBJECTIVES AND DELIMITATIONS	5
1.3 OUTLINE OF THE THESIS	6
1.4 CONTRIBUTIONS.....	7
1.5 PUBLICATIONS.....	8
CHAPTER 2 POWER SYSTEM FREQUENCY DYNAMICS.....	9
2.1 POWER BALANCE	9
2.2 FREQUENCY RESPONSE INDICATORS	12
2.3 FREQUENCY CONTROL AND RESERVES	13
2.4 SUMMARY	16
CHAPTER 3 NORDIC TEST SYSTEM.....	17
3.1 NORDIC POWER SYSTEM OVERVIEW	17
3.2 PRODUCTION UNITS AND LOAD MODELLING	18
3.3 TEST SYSTEM STRUCTURE AND MODEL REDUCTION	22
3.4 SYSTEM MODELS	25
3.5 DISCUSSION.....	32
CHAPTER 4 INDUCTION GENERATOR FREQUENCY RESPONSE.....	33
4.1 GENERIC TEST SYSTEM.....	33
4.2 SIMULATIONS.....	35
4.3 LABORATORY TEST.....	36
4.4 SUMMARY	37
CHAPTER 5 NATURAL INERTIA.....	39
5.1 ACCEPTABLE FREQUENCY	39
5.2 NORDIC POWER SYSTEM INERTIA.....	40
5.3 SIMULATIONS WITH DISTURBANCE AT 50.0 HZ.....	41
5.4 SIMULATIONS WITH DISTURBANCE AT 49.9 HZ.....	45
5.5 DISCUSSION.....	46

CHAPTER 6 SYNTHETIC INERTIA	47
6.1 DF/DT-CONTROLLER	47
6.2 STUDY CASE	50
6.3 SIMULATION WITH DF/DT-CONTROLLER.....	51
6.4 RESPONSE TO MEASURED FREQUENCY	55
6.5 SYNTHETIC INERTIA BASED ON DIRECTLY MEASURED FREQUENCY	57
6.6 SYNTHETIC INERTIA BASED ON AVERAGE FREQUENCY.....	59
6.7 SYNTHETIC INERTIA BASED ON LOW-PASS FILTERED FREQUENCY	66
6.8 SUMMARY	72
CHAPTER 7 FREQUENCY SUPPORT	75
7.1 INTRODUCTION TO FREQUENCY SUPPORT.....	75
7.2 SIMULATING IMPACT OF CONTROLLER ON SYSTEM FREQUENCY	78
7.3 ΔF -CONTROLLER WITH SMOOTHER RECOVERY	83
7.4 GENERALLY DEFINED FREQUENCY SUPPORT CONTROLLER ...	86
7.5 CURTAILED WIND POWER WITH DROOP CONTROL.....	93
7.6 SUMMARY	95
CHAPTER 8 DISCUSSION.....	97
8.1 PERFORMANCE OF INVESTIGATED CONTROLLER TYPES.....	97
8.2 TSO REQUIREMENTS ON SYNTHETIC INERTIA	99
8.3 RECOMMENDATIONS	100
8.4 VERIFICATION OF SYNTHETIC INERTIA RESPONSE.....	101
8.5 VALIDITY OF RESULTS	101
8.6 SUMMARY	102
CHAPTER 9 CONCLUSIONS.....	103
9.1 SUMMARY OF RESULTS	103
9.2 FUTURE WORK	105
REFERENCES.....	107
APPENDIX.....	113

Chapter 1

Introduction

In this first chapter the background and the motivation of the work is introduced, followed by the objectives, delimitations and the outline of the thesis. The main research contributions are also summarized.

1.1 Motivation

Electric power systems have been around for over one hundred years, are well known and well working. Nevertheless, even in the most excellent system some changes to be handled may be introduced over the time. As in many other fields much of the changes regarding electric power systems are motivated by environmental concern. This implies new production types and new utilization of existing production units.

Most dominating among the new energy sources is wind power but also other small units may contribute to reduce production based on less environmental friendly fuel such as coal and oil. Common for many of these units is that they are non-synchronously connected to the power system, unlike the traditional generation based on large synchronous generators. This may affect the power system in various ways and one of them is the impact on frequency.

The power balance in a conventional power system is determined by

$$J\omega_{nom} \frac{d\omega}{dt} = P_{mech} - P_{el} \quad (1.1)$$

where J [kgm^2] is the total inertia of the rotating masses, ω [rad/s] the speed and P_{mech} [W] and P_{el} [W] is the mechanical and electrical power respectively.

Kinetic energy is stored in the rotating masses of all synchronously connected machines in the system. If the load in the system suddenly exceeds the

production a mismatch between P_{mech} and P_{el} appears. Kinetic energy will be released and transferred as electric energy to the power system. Since the turbine governors are slow, the initial power increase is solely obtained by this inertial response. During this process the generator speed decreases and so does the electric frequency. Some seconds after the disturbance, primary frequency control makes the turbine governors increase power from the turbines and the frequency is restored to a value close to nominal.

The frequency behaviour during the first seconds after the disturbance, is determined only by the inertial response and hence the amount of stored kinetic energy. Higher system inertia gives lower rate of change of frequency and higher frequency nadir, i.e. the lowest frequency, since the turbine governors are given more time to act and restore the frequency. It is important to maintain the frequency within given limits. At a frequency below a certain critical level, production units will be disconnected which in turn will aggravate an already low frequency and in the worst case will end up in a blackout.

The natural inertial frequency response described above is not necessarily obtained from non-synchronously connected generation which in some cases lack all connection between rotational speed and electrical frequency, i.e. (1.1) is not valid.

In the early days of wind power the fixed speed induction generator (FSIG) concept was dominating. However, since the optimal wind turbine speed, giving maximum power extraction, is dependent on the wind speed it is not preferable with one single operation speed. As power electronics developed it became possible to allow variable speed operation of a wind turbine by means of a doubly-fed induction generator (DFIG). It was then possible to increase the efficiency over a wider range of wind speeds. In a DFIG the wound rotor of an induction generator is connected to the grid by means of a power electronic converter. The DFIG concept is actually not new but gained popularity when the power electronics eliminated the need of e.g. a single-armature converter (Alm 1956). A DFIG wind turbine is normally made for variable speed operation in the range of 0.7-1.3 times nominal speed. Hence the converter rating is limited to 30% of generator rated power. As the power electronic converters became less expensive it was possible with a converter rated for the total generator power and the full scale converter (FSC) concept was developed. In combination with FSC a synchronous generator is often used.

In a DFIG the stator is directly connected to the grid but due to a fast active

power control of the rotor side converter the connection between generator speed and grid frequency is removed. The generator power is determined by the converter control. In an FSC all power is transferred through the converter and no connection between generator speed and grid frequency exists. Hence no inertial response is obtained from DFIG or FSC and larger frequency excursions are expected as the level of such generation increases.

The inertia constant H of a wind turbine is in the order of 2-6 s (Morren et al. 2006) which is comparable to traditional generation with 2-10 s (Kundur 1994). Hence the kinetic energy in the rotor is high enough to support the frequency but has to be released by means of control actions in the converter active power control to mimic inertia. In the inertial response, a part of the kinetic energy stored in the turbine is released by temporarily increasing the output power. As energy is released from the rotor the speed decreases. Consequently the overproduction period has to be followed by a period of underproduction where the turbine speed is increased and the energy in the rotating mass is restored.

Over the last years many papers on wind power and synthetic inertia have been presented. Since many of these papers are similar only a selection of them are listed here. (Ekanayake et al. 2004) shows that a DFIG with a supplementary torque controller can supply considerably greater kinetic energy than an FSIG during a frequency disturbance. In (Lalor et al. 2005) the influence of FSIG and DFIG on frequency dynamics in the Irish system is studied and it is concluded that modification of the wind turbine controllers may become necessary as the wind power penetration increases. A comparison of different control algorithms intended to make variable speed wind turbines behave as synchronous generators with frequency control is presented in (Morren et al. 2006). Spinning reserve from a wind turbine is also possible (Ramtharan et al. 2007). The pitch angle is then increased to run the turbine with higher speed and lower output power, i.e. below the maximum power point. Whenever the reserve is required the stored kinetic energy may be released fast.

The wind turbine ability to support frequency is quantified in (Ullah et al. 2008) and (Tarnowski et al. 2009) A possible overproduction of 0.1-0.2 pu for at least 10 s is indicated.

DFIG has received significant attention in many papers and in (Conroy et al. 2008) the frequency control capability of FSC is compared to that of synchronous generators. With additional frequency control activated by a frequency deviation, wind power can improve the initial frequency support.

Even though much work around grid support capability concerns variable speed wind turbine, it is also possible to provide support to the grid during a disturbance by means of utilizing FSIG (Hansen et al. 2006).

Traditionally oscillations excited by a transient fault are damped by the conventional power plants. In (Jauch et al. 2007) damping controllers for variable speed wind turbines are developed. Hence the reduction of power system damping when introducing wind power is avoided. Transient stability in the Nordic power system is investigated by (Jauch et al. 2007) and (Ullah et al. 2008). A small signal stability analysis of the impact of wind power in the Nordic system is performed by (Hagstrøm et al. 2005) where the inter-area oscillations between Sweden-Norway and Sweden-Finland are studied.

Frequency dynamics in a system with high wind power penetration has been studied for a generic model of Denmark (Divya et al. 2008). The result shows that FSIG and DFIG will increase the frequency deviation at the event of a power imbalance in the system. The impact of wind power on frequency dynamics in the Nordic power system is also studied in (Ullah 2008) by means of the power system model Nordic32. The wind turbine is equipped with a controller for temporary primary frequency control.

Also wind turbine manufacturers such as ENERCON, Vestas, GE and Siemens have shown interest in frequency support (Wachtel et al. 2009), (Tarnowski et al. 2010), (Miller et al. 2011), (Knüppel et al. 2011). REpower and ENERCON have cooperated with Hydro Québec and simulated frequency support controllers in the power system of Québec (Dernbach et al. 2010), (Fecteau et al. 2010). A recent review on inertia control for wind turbines is presented in (Christensen et al. 2011).

Synthetic inertia is certainly of academic interest, but also TSOs have shown interest in this question (Brisebois et al. 2011), (National Grid 2011), (ENTSO-E 2011).

In the literature there are mainly two controller types for eliminating the negative influence on frequency with increasing wind power penetration. The first one is to temporarily increase active power related to the rate of change of frequency (df/dt). The second one, which actually behaves much like traditional frequency control, implies controlling active power related to frequency deviation (Δf). A variant of the Δf -controller is the bang-bang control which can be regarded as a Δf -controller with infinite gain.

As a conceptual confusion about synthetic inertia controllers easily arises,

only the df/dt -controller is here regarded as synthetic inertia controller. A Δf -controller can only improve the frequency nadir, not the initial df/dt , and is therefore designated frequency support controller. This terminology is used throughout the thesis when discussing the different control strategies.

There are two options when investigating synthetic inertia and frequency response, study the behavior of e.g. a wind turbine or a wind farm with a given frequency or involving a model of the power system and hence frequency feedback. Both approaches are used in the references given above but for a system with high level of wind power frequency feedback is essential. In this thesis a simple model of the Nordic power system is used.

1.2 Objectives and Delimitations

This thesis is dealing with the impact on power system frequency dynamics with increasing amount of non-synchronously connected production units. For a thesis from Sweden it seems natural to focus on the Swedish situation. However, the Swedish power system is synchronously connected to Norway, Finland and the east of Denmark. Frequency dynamics is therefore a Nordic problem rather than a Swedish problem and the whole Nordic synchronous area has to be considered simultaneously.

The main objectives of the thesis are to:

- Investigate the difference in frequency response of a synchronous and an induction generator.
- Analyze and evaluate different control strategies for synthetic inertia.
- Analyze and evaluate different control strategies for frequency support.
- Identify and suggest recommendations on a control strategy for future wind power.

The evaluations are based on a future scenario with high level of wind power in the Nordic system.

Limitations due to transfer capacity are disregarded in the model of the Nordic system in this thesis. This is a problem that has to be dealt with also today and is not affected by the production being synchronous or not.

The fact that production and consumption do not entirely match all the

time, leads to slow frequency variations. These slow frequency variations are not included in what is here designated as frequency dynamics. Nor is the fluctuating nature of the wind that also contributes to these variations. The frequency events studied here are the large ones occurring at loss of a production unit or a load area. These are the severe ones from a system stability point of view as they in the worst case can lead to a blackout. Key indicators of these frequency events are maximum frequency gradient (df/dt) and maximum frequency deviation.

1.3 Outline of the Thesis

The fundamentals of power system frequency dynamics and frequency control are described in Chapter 2.

The simulation models to be used later on are described in Chapter 3. This includes power system modelling and modelling of different types of generation. The influence of load voltage dependency is investigated in some simulations to determine which level of simplification to be used in the system model.

Although much of the new generation is connected to the grid with power electronic converters also the amount of induction generators in the system is expected to increase. This is mainly the case with smaller hydropower stations where an old synchronous generator is often replaced by an induction generator as the stations are modernized. How this affects the frequency dynamics is investigated in Chapter 4 where the induction generator frequency response is studied.

In Chapter 5 the influence of decreasing natural system inertia is studied for different load situations and different turbine governor frequency response.

In Chapter 6 the synthetic inertia control is described and evaluated. Some problems related to the df/dt -controller are also studied.

Different control schemes for frequency support are investigated in Chapter 7.

In Chapter 8 the different control strategies from Chapter 6 and 7 are discussed and some recommendations are given. Opinions from some TSOs regarding synthetic inertia are also reviewed.

Finally, conclusions and some ideas for future work are presented in

Chapter 9.

1.4 Contributions

When talking about increasing amount of wind power in the system a common question is: *What is the maximum possible amount of wind power in the system?* This is a question involving many factors and therefore without any simple answer. However, hopefully some issues regarding frequency dynamics will be clarified, which is at least a part of the answer to this question. The main contributions of this thesis are as follows:

- The frequency response of an induction generator and a synchronous generator are compared. In laboratory tests it is shown that the synchronous and induction generator capability of delivering power to the grid during a frequency disturbance is almost exactly the same given equal mechanical systems.
- The quantitative influence of system inertia and turbine governor control on frequency dynamics in the Nordic system is shown. For this analysis wind power is of less direct importance.
- The performance of, and problems related to, synthetic inertia control are studied from the power system point of view. The df/dt -controller acts on low frequency oscillations which is not always preferable. However, a positive side effect of this controller is that it improves the damping in the system.
- It is shown that if measured frequency is filtered prior to the df/dt calculation the synthetic inertia response is delayed which increases the response of the hydro turbines and actually improves the frequency dynamics.
- A frequency support controller acting on Δf is shown to improve the frequency nadir. However the tuning of this controller is very critical if not used in combination with curtailed wind power.
- It is demonstrated that a df/dt -controller or Δf -controller giving high and fast power increase is not always the best for the overall frequency dynamics. When ordering high additional power the traditional turbine governors sees a smaller frequency deviation than without any wind turbine control and does not initially increase their power as much as preferable. In such a case the wind turbine control will postpone and

make the frequency problem worse. When investigating synthetic inertia and frequency support in a system with high level of wind power the entire system has to be considered.

While this work is mainly motivated by the wind power expansion, many of the results are very general and not related only to the nature of wind power.

1.5 Publications

This work has partly been reported in:

Björnstedt J., Samuelsson O. (2011). “Rate of change of frequency and frequency deviation in the Nordic power system with increasing wind power”, *10th International Workshop on Large-Scale Integration of Wind Power into Power Systems*, Aarhus, Denmark, 25-26 October.

The following publications are not directly related to this work:

Björnstedt J., Samuelsson O. (2008). “Voltage and frequency control for island operated induction generators”, *CIREC Seminar 2008*.

Björnstedt J., Samuelsson O. (2008). “Semi-Kaplan Turbine Governor Controlling an Island Operated Induction Generator”, *NORDAC 2008*.

Sulla F., Björnstedt J., Samuelsson O. (2010). “Distributed Generation with Voltage Control Capability in the Low Voltage Network”, *International Conference on Renewable Energies and Power Quality (ICREPQ'10)*, Granada, Spain.

Björnstedt J., Sulla F., Samuelsson O. (2011). “Experimental investigation on steady-state and transient performance of a self-excited induction generator”, *IET Generation, Transmission & Distribution*, vol 5, issue 12, pp. 1233 – 1239.

Chapter 2

Power System Frequency Dynamics

This chapter gives an introduction to the frequency dynamics and frequency control of a power system. The requirements on frequency control, given in this chapter, are valid for the Nordic system.

2.1 Power Balance

A transmission line is mainly inductive and its active power transfer is given by

$$P = \frac{V_1 V_2}{X_L} \cdot \sin \theta \quad (2.1)$$

where V_1 and V_2 [V] are the end voltage magnitudes, X_L [Ω] the line reactance and θ [rad] the angle difference between V_1 and V_2 .

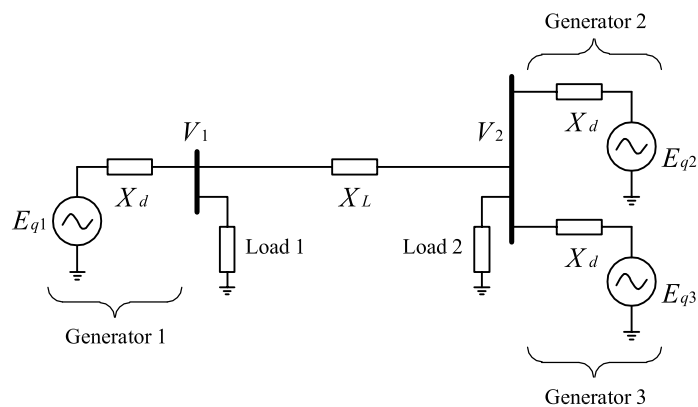

Figure 2.1 Simple power system model.

If generator 3 in Figure 2.1 is suddenly disconnected the angles of V_1 and V_2 will change rapidly as the power transfer over the line reactance X_L changes. The same expression as in (2.1) holds for a synchronous generator when ignoring saliency. δ is then the angle difference between the induced voltage E_q and the terminal voltage V .

$$P_e = \frac{E_q V}{X_d} \cdot \sin \delta \quad (2.2)$$

As the rotor in the generator has inertia, the angle of the induced voltage E_{q1} cannot change rapidly. Hence, a reduced V_1 angle (associated with e.g. loss of generator 3) implies an increased output power from the generator. The turbine governor cannot increase the input power instantaneously, hence the additional power has to be extracted from the kinetic energy stored in the rotor. The rotor speed decreases and so does the electrical frequency as well due to the strong connection between mechanical and electrical frequency in the synchronous generator.

The mechanical system is described by

$$J\omega_{nom} \frac{d\omega}{dt} = P_{mech} - P_{el} \quad (2.3)$$

which implies that a difference between mechanical power (P_{mech}) and electrical power (P_{el}) gives a change in speed. J is the rotor inertia and ω the rotor speed.

If the electrical load P_{el} power is increased without increasing the mechanical power P_{mech} from the turbine a power unbalance arises and the speed of the generator decreases. Likewise, for the case with higher mechanical than electrical power, the rotational speed increases. An electrical frequency change (df/dt) is a measure of a power imbalance in the system.

For a single generator, J may be replaced by an inertia constant H and the generator rated power S_n .

$$J = \frac{2S_n H}{\omega_{nom}^2} \quad (2.4)$$

which leads to

$$\frac{2S_n H}{\omega_{nom}} \frac{d\omega}{dt} = P_{mech} - P_{el} \quad (2.5)$$

H is given in seconds and is a measure of the time that a rotating generator can provide rated power without any input power from the turbine.

Instead of using J for inertia $S_n H$ is used in this thesis from now on. This facilitates the calculations and it is easy to see the connection between rated power and inertia. It is also easy to calculate an equivalent inertia of a system comprising generators with different S_n and H . Equation (2.5) may then represent an equivalent of a power system with several synchronously connected rotating machines and the equivalent $S_n H$ is calculated as

$$S_n H = S_{n1} H_1 + S_{n2} H_2 + \dots + S_{nN} H_N \quad (2.6)$$

where S_{nN} and H_N is the rated power and inertia constant for generator N .

Since the power system is supposed to handle a specific loss of production, i.e. the rating of the largest connected unit, it is preferable to use $S_n H$ instead of the inertia constant H as a measure of the system strength. It is then easy to relate the disturbance magnitude in MW to the system inertia in MWs.

An example of the frequency behaviour following a loss of generation is shown in Figure 2.2. The primary frequency control is here obtained with hydropower units. Immediately after tripping one generator the remaining generators increase their output power by releasing kinetic energy stored in the rotor. The electrical output power is then higher than the mechanical turbine power and the generator speed and grid frequency decreases. This is between 0 and 10 s in Figure 2.2

With a short delay the turbine gate opening is increased but due to the non-minimum phase characteristic of a hydro turbine the mechanical power is initially decreased prior to increasing. With increasing turbine power the rate of change of frequency is decreased. When the mechanical power is equal to electrical power the frequency nadir, i.e. the lowest frequency, is reached. After this point the mechanical power is higher than the electrical power, the kinetic energy previously released from the rotor is restored and the frequency is increased. Finally the frequency stabilizes at a value where the mechanical

power and the electrical power are equal. This control action is called primary control. The size of the stationary frequency error is determined by turbine governor droop function. Due to the intentional frequency error equal generator load sharing, in pu on machine base, is possible without involving any communication.

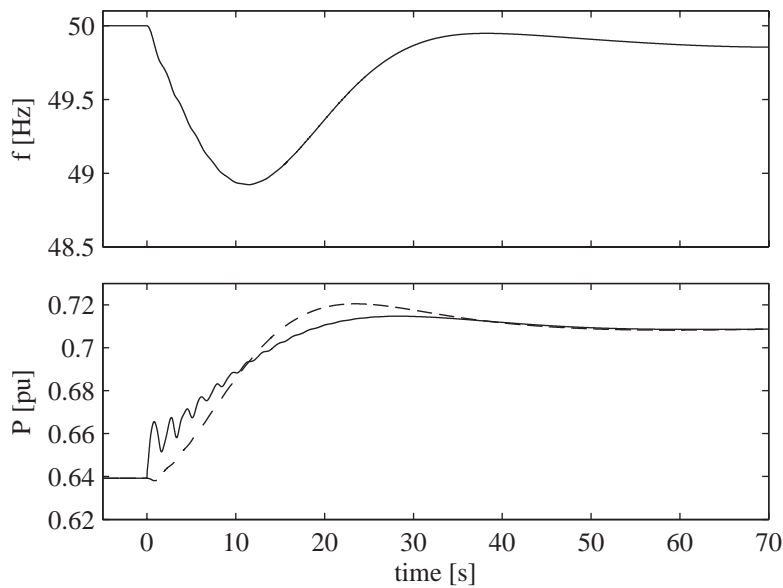

Figure 2.2 Simulation of loss of generation in a system with frequency control from hydropower units. Top: frequency. Bottom: turbine power (dashed) and electric output power (solid).

The stationary error is removed by increasing the turbine governor set points. By the action of this secondary control the reserve for primary control is released and the system is prepared for a new disturbance.

2.2 Frequency Response Indicators

When evaluating frequency response the important indicators are maximum frequency gradient (df/dt) as observed by ROCOF (Rate-Of-Change-Of-Frequency) relays and maximum frequency deviation as observed by underfrequency relays. Both these quantities shall be kept as small as possible to prevent relays from tripping. df/dt , frequency deviation and frequency nadir are defined in Figure 2.3.

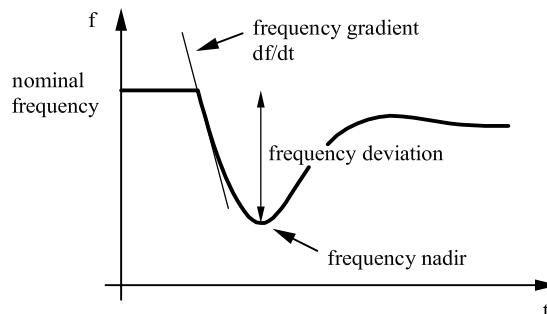

Figure 2.3 Frequency response indicators.

2.3 Frequency Control and Reserves

Previously a short introduction to frequency dynamics was given. To ensure that an acceptable frequency is maintained during a disturbance, i.e. loss of generation or load, import or export, control reserves have to be continuously available. The required reserves in the Nordic system, given in the System Operation Agreement (Nordel 2007), are summarized below.

Primary Control

In the Nordic power system the frequency is allowed to vary within 49.9 - 50.1 Hz with an average of 50.0 Hz. The primary control is used to compensate for normal load variations in order to fulfill these requirements.

Secondary control

To ensure a 50 Hz average the time deviation is used. The maximum allowed time deviation, defined as the difference between an electric synchronous clock and the astronomic time, is ± 30 s.

When the frequency or the time deviation is getting near their limits the production is changed with the secondary control in order to release primary control capacity. While most other systems use automatic secondary control (Automatic Generation Control – AGC), the secondary control in the Nordic system is manual¹. Secondary control would be used to restore the frequency in Figure 2.2 to 50.0 Hz.

¹ AGC in the Nordic system is going to be introduced from January 1, 2013.

Reserves

For an overfrequency event it is possible to reduce the generated power fairly fast to reduce the high frequency. For underfrequency, on the other hand, reserves have to be available in order to increase the production. Hence this is the major challenge and this work focuses on underfrequency. The reserves for handling normal load variations and faults are divided according to the following.

Frequency Controlled Normal Operating Reserve

The *frequency controlled normal operating reserve* is used to compensate for normal load variations. This reserve of at least 600 MW at 50 Hz shall be completely activated at 49.9 and 50.1 Hz respectively.

Frequency Controlled Disturbance Reserve

The system shall be capable of handling a dimensioning fault, i.e. loss of the largest synchronized production unit. For this purpose the *frequency controlled disturbance reserve* is kept. The reserve shall equal at least the dimensioning fault subtracted by 200 MW. The reduction of 200 MW is due to the self control from the frequency dependent load. The dimensioning fault is determined by the largest unit synchronized at the moment which implies that it will change with time. At the moment the largest nuclear unit in the Nordic system is rated 1 400 MW thus determining the largest possible dimensioning fault².

The reserve is activated at 49.9 Hz, and increases linearly to be fully activated at 49.5 Hz. Some thermal power on Zealand is used in this reserve but the reserve is mainly obtained by hydropower stations normally operating below their rated power. Load shedding may also be used as *frequency controlled disturbance reserve*.

If the frequency drops to 49.5, due to a momentary loss of production, 50% of the *frequency controlled disturbance reserve* shall be activated within 5 s and 100% within 30 s.

Fast Active Disturbance Reserve

The *fast active disturbance reserve* is used to restore the *frequency controlled normal operating reserve* and the *frequency controlled disturbance reserve*. This

² Olkiluoto 3 in Finland is rated 1 600 MW but load will be disconnected simultaneously with the generator to maintain the dimensioning fault level.

reserve shall be available within 15 min.

Slow Active Disturbance Reserve

The *slow active disturbance reserve* shall be available after 15 min and is used to restore the *fast active disturbance reserve*.

In this work, considering frequency dynamics, only the time up to some tens of seconds after a fault is interesting. Hence only *frequency controlled normal operating reserve* and *frequency controlled disturbance reserve* have to be considered, see Figure 2.4.

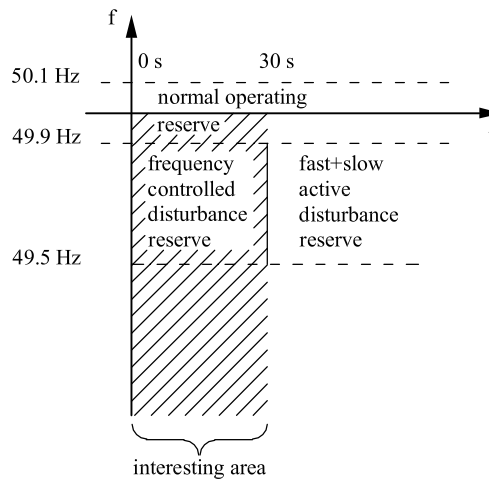

Figure 2.4 Reserve operating areas and time and frequency ranges of interest in this work assuming a frequency disturbance at $t=0$ s.

Frequency Response

The *frequency response* is given in MW/Hz and determines how the reserve is activated as a function of frequency. Given a *frequency controlled normal operating reserve* of 600 MW completely activated at 49.9 Hz the *frequency response* is 6 000 MW/Hz. The droop setting in the turbine governors has to be chosen to meet this requirement.

Although the required minimum frequency response is 6 000 MW/Hz it may be as high as 12 000 – 14 000 MW/Hz in a high load situation (Nordel 1997). The frequency response for the *frequency controlled normal operating reserve* and the *frequency controlled disturbance reserve* is visualized in Figure 2.5. The frequency response for the *frequency controlled disturbance reserve* will

vary as the reserve requirement varies but 3 000 MW/Hz is the highest frequency response that can be required.

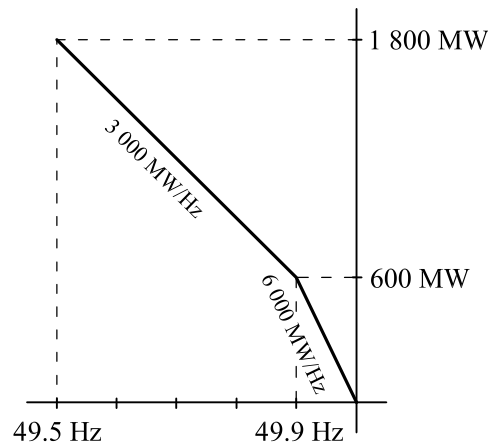

Figure 2.5 Frequency response for frequency controlled normal operating reserve and frequency controlled disturbance reserve in the Nordic power system.

2.4 Summary

Frequency dynamics basics along with Nordic frequency control are now introduced. By frequency dynamics is here meant the first tens of seconds following a major loss of generation. In the next chapter modelling of frequency dynamics in a power system in general and in the Nordic system in particular, will be explained.

Chapter 3

Nordic Test System

In this chapter the simulation models to be used later on are described. This includes modelling of the Nordic synchronous area and modelling of different types of generation – hydro, thermal and wind. The influence of load voltage dependency is also investigated to determine which level of simplification to be used in the system model. First the installed generation capacity and load power today and in the future is discussed in order to define a scenario representative around year 2025.

3.1 Nordic Power System Overview

As previously mentioned it is not possible to study frequency dynamics in the Swedish system exclusively. The entire Nordic synchronous area has to be simultaneously handled. This includes Sweden, Norway, Finland and the east of Denmark. The connection between Eastern Denmark (Zealand) and Western Denmark (Funen and Jutland) is HVDC hence decoupling west Denmark from the rest of the Nordic system.

Production Capacity

The installed conventional production in the Nordic synchronous area is about 49 000 MW hydropower and 42 000 MW nuclear and other thermal power (Svensk Energi 2010). The amount of wind power is steadily increasing and the increase in installed wind power was 16% in year 2011 so that at the end of that year the installed wind power capacity in the Nordic synchronous area was 4 800 MW (EWEA 2012). It is then assumed that 30% of the wind power in Denmark is located on Zealand.

In Sweden wind power is estimated to increase from today's 2 900 MW to 8 000 MW in year 2024 (Svensk Energi 2011). The Danish Energy Authority's goal for renewable power production implies an expansion of

wind power from today's 3 900 MW to 6 000 MW in 2025 (EA Energy Analysis 2007) (this includes Jutland/Funen as well). The expansion in Norway and Finland is expected to be more moderate. With these figures in mind a reasonable assumption for year 2025 is in total 15 000 MW wind power in the Nordic synchronous area. This is used as maximum wind power capacity in the simulations.

The maximum load in the Nordic system is about 60 000 MW and the minimum load about 30 000 MW. Problems related to frequency dynamics are worst in low load situations with high production from non-synchronously connected generation. Despite increased efficiency of electric loads in the future the total load is probably not decreased due to the addition of new loads e.g. electrical vehicles. Hence the minimum load holds as a worst case scenario also in the future.

Forecasting is always difficult but the assumptions regarding future wind power penetration is not critical to the results and conclusions given later on.

3.2 Production Units and Load Modelling

Prior to modelling the power system, the modelling of components in the system is described. This includes hydropower, thermal power, wind power and load modelling. The modelling of hydropower and load is adopted from the well documented CIGRÉ model Nordic32 (CIGRÉ 1995) developed by the Swedish TSO. The model was primarily developed to reproduce the voltage collapse of 27 December 1983 and contains both hydro and nuclear units with relevant controllers.

Hydropower

The hydro turbine governor is modelled according to Figure 3.1 with the parameters listed in Table 3.1. This is a standard governor model with permanent and temporary droop.

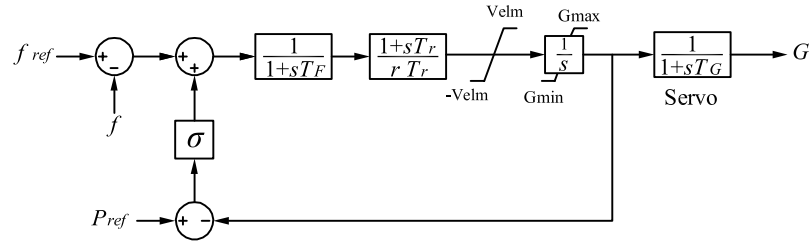

Figure 3.1 Hydro turbine governor model.

Table 3.1 Governor parameters.

Filter time constant (T_F)	0.05 s
Servo time constant (T_G)	0.2 s
Permanent droop (σ)	0.04
Temporary droop (r)	0.4
Temporary droop time constant (T_r)	5 s
Gate velocity limit (Vel _m)	0.1 pu/s
Maximum gate limit (G _{max})	1
Minimum gate limit (G _{min})	0

The permanent droop (σ) is the steady-state frequency deviation in pu giving a 1 pu change in gate opening.

$$\sigma = \frac{\Delta f \text{ [pu]}}{\Delta P \text{ [pu]}} \quad (3.1)$$

Normal values for σ are around 0.05. The governor frequency response (R) is the inverse to the permanent droop.

$$R = \frac{\Delta P \text{ [MW]}}{\Delta f \text{ [Hz]}} = \frac{1}{\sigma} \cdot \frac{P_n}{f_n} \quad (3.2)$$

Thermal power has long thermal time constants and is therefore less suitable for fast frequency control. The time constant in hydropower on the other hand is in the order of seconds. Hence the primary frequency control in the Nordic synchronous area is mainly concentrated to hydropower. In the simulations it is assumed that frequency control is entirely obtained by hydropower although, in the real system, other power plants and HVDC

links are used as disturbance reserve as well.

Hydro turbine and waterways are modeled according to Figure 3.2. This is a standard non-linear model assuming an inelastic water column (IEEE 1992). Parameters are given in Table 3.2. The hydropower inertia constant is assumed to be 3 s (CIGRÉ 1995).

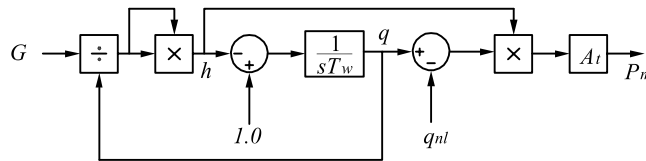

Figure 3.2 Hydraulic turbine model.

Table 3.2 Hydro turbine parameters.

No-load flow (q_{nl})	0
Water time constant (T_w)	1.0
Turbine gain (A_t)	1.0

The hydropower is split into three parts, one for *frequency controlled normal operating reserve*, one for *frequency controlled disturbance reserve* and one operating at constant power. The *frequency controlled normal operating reserve* is fully activated at 49.9 and 50.1 Hz respectively while the *frequency controlled disturbance reserve* has a deadband of 0.1 Hz.

The amount of hydropower participating in the frequency control is chosen so that the reserve and frequency response requirements in the Nordic System Operation Agreement (Nordel 2007) are just met. This implies a normal operating reserve of 600 MW with 6 000 MW/Hz and a disturbance reserve of 1 200 MW with 3 000 MW/Hz frequency response. Using $\sigma=0.04$ results in the values given in Table 3.3

Table 3.3 Hydropower for frequency control.

	Normal op. reserve	Disturbance reserve
Installed capacity (P_n)	12 000 MW	6 000 MW
Production (P)	11 400 MW	4 800 MW
Permanent droop (σ)	0.04	0.04
Reserve	600 MW	1 200 MW
Frequency response (R)	6 000 MW/Hz	3 000 MW/Hz

Thermal Power

Throughout this work it is assumed that all frequency control is provided by hydropower and all thermal and nuclear units are operated at constant power. Hence no steam turbine model is included. In fact some thermal plants on Zealand and in Finland do contribute to the *frequency controlled disturbance reserve*. The inertia constant for thermal and nuclear units is assumed to be 6 s (CIGRÉ 1995).

Wind Power

The wind turbine model comes from the SIMULINK toolbox SIMWINDFARM, developed as a part of the EU FP7 project Aeolus at Aalborg University (Grunnet et al. 2010), (Aeolus). The 5 MW wind turbine model is a simplified aero elastic model based on lookup tables for the aerodynamics, a 3rd order drive train model, a 1st order generator model, 1st order pitch actuator, and 2nd order tower dynamics, see Figure 3.3. This is a FSC turbine but as the power electronic converter dynamics is assumed to be much faster than the frequency dynamics of interest and the rest of the system, the converter is not modeled explicitly. It is assumed that power fed into the system equals generator output power.

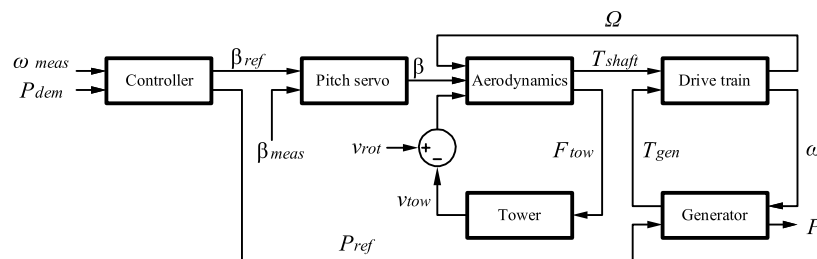

Figure 3.3 Wind turbine model (Grunnet et al. 2010).

Although this is a FSC model most of the control is similar to a DFIG (Ullah et al. 2008). Therefore the simulation results obtained with this model also holds for DFIG turbines.

When studying the Nordic power system the behavior of one single wind turbine is of less importance. To aggregate all wind turbines in an area the output power from the single turbine model is simply multiplied by an appropriate factor. As dynamics inside a wind farm are not studied, this approximation is acceptable.

The wind turbine may be operated at a point determined by the optimum speed curve and hence extracting maximum power from the wind, or in curtailed mode with a constant power set point. When operating in curtailed mode or at high wind speeds the output power is controlled and limited by adjusting the pitch angle.

Load

The active load is assumed to vary with frequency as

$$P = P_0 \left(1 + k_{pf} \frac{f - f_n}{f_n} \right) \quad (3.3)$$

with $k_{pf} = 0.75$ (CIGRÉ 1995). This implies that at a frequency deviation there will be a natural contribution to frequency control from the load, caused by its frequency dependence.

3.3 Test System Structure and Model Reduction

Using a model such as Nordic32 to investigate the influence of non-synchronously connected generation on frequency dynamics is not straightforward. The location of the new introduced generation has to be carefully decided to avoid problems related to e.g. voltage and transfer limitations. Such issues are important but not directly related to frequency dynamics and can make the understanding of the main problem difficult. A more simplified system model offers more freedom to introduce new production and change existing production and load. Hence it is easier to focus on the question to be investigated, i.e. frequency dynamics. When investigating frequency dynamics explicit representation of the system inertia and turbine controllers are important while the representation of individual generators is of less importance. Hence it is possible to use a simplified system model without risking the reproduction of the phenomenon to be investigated.

A model with several rotating masses is essential when investigating power system oscillations. In this case where oscillations are of less interest it is possible to aggregate all rotating machines in the system into one single mass. The system is then represented with the swing equation (2.5). Despite the single mass representation different areas and a load flow calculation is still possible. A further simplification is to assume a fast voltage control maintaining the voltage close to its nominal value.

Omitting explicit representation of voltage leads to a simple and easy to use simulation model. The drawback with this assumption is that the voltage dependence of the load does not help in reducing the frequency deviation subsequent to a disturbance. Thus a slightly larger frequency deviation is expected when assuming constant voltage. Consequently such a model gives a slightly more pessimistic result regarding frequency deviation than what would be the case if voltage was included.

When omitting voltage representation a power system can be modelled according to (Assdourian 2005). This approach is here described for the simple three area system in Figure 3.4, where all areas are interconnected with three transmission lines. The same approach can be used for any number of areas. For each area the net generated power, i.e. generation minus load and losses, is calculated. The net generation from all areas are then added to the total accelerating power, i.e. the power imbalance in the system.

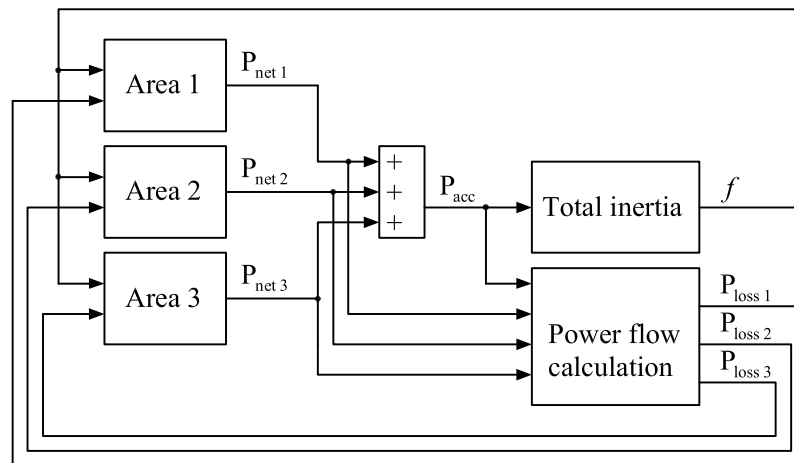

Figure 3.4 Power system model with 3 areas.

For a system in steady state the accelerating power is zero and the frequency is stable. If a disturbance occurs somewhere in the system a power imbalance will arise. The frequency is determined by integration of the power imbalance according to Figure 3.5. $S_n H$ represents the total inertia of all the rotating machines in the system, where H is the inertia constant and S_n the rated power. The total flywheel mass is calculated as in (2.6).

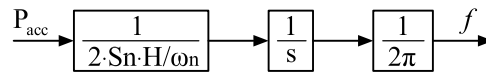

Figure 3.5 Total system inertia.

Each area in the model is composed of aggregate models of hydro turbines, steam turbines, wind turbines and loads, see Figure 3.6. An extra term can be added to the power balance to simulate an ideal HVDC connection to an adjacent area or system. The net load from each area is calculated as the production subtracted by the load power.

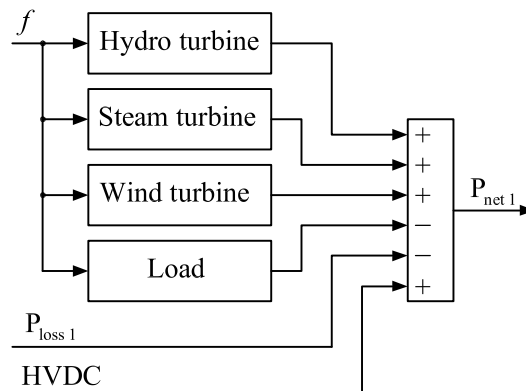

Figure 3.6 Power balance in one area with generation and load models.

To determine the losses in the transmission lines the power flow in each line has to be determined. The power transferred from one area to another can be split on several parallel lines with a distribution determined by the line reactance. The power flow and line losses are calculated according to Figure 3.7.

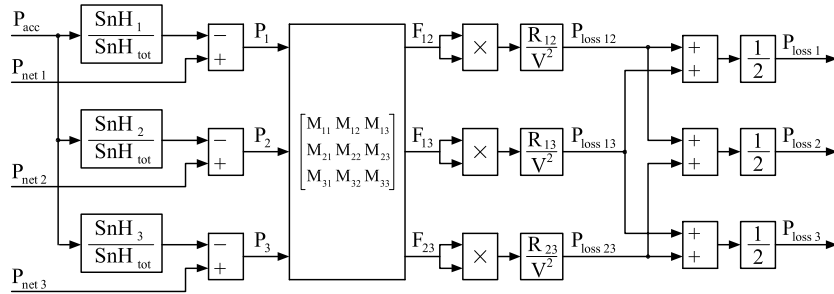

Figure 3.7 Power flow calculation.

The total accelerating power is divided on the different areas according to the area inertia. The accelerating power for each area is subtracted from the net generation in the corresponding area to determine the power imbalance (P) in each area. Power flow (F) is then calculated by means of the distribution matrix (M). The procedure for determining M is described in the appendix.

With the power flow in each line known the transmission losses are calculated from the line resistances. These losses are fed back as an extra load. Half of the loss in a line is added to each of the two adjacent areas.

3.4 System Models

To determine an appropriate level of model complexity three models with different simplifications are studied. For simplicity the models to be evaluated are named according to the number of areas and masses, i.e. Nordic "areas"/"masses".

As mentioned earlier Nordic32 is a well documented model, however intended for transient stability and long term stability studies with focus on Sweden. Hence the rest of the Nordic synchronous area is very simplified. Further the generation capacity and inertia do not match those of the real system. Instead a Nordic model with 23 generators, developed at SINTEF Energy Research in several steps starting with the model in (Bakken 1997), is used as base for the studies here. The model was originally designed for studying transmission capability and later on frequency dynamics and damping.

Nordic21/21 model

In the original 23 generator model eight generators are located in Sweden, ten in Norway, two in Finland, two in Denmark and one in Germany. This model is imported into POWERFACTORY 14.0 (DigSilent 2010) from PSS/E and Germany and the west of Denmark are removed as they are connected with HVDC links, i.e. not synchronously connected to the rest of the Nordic system. This gives a model with 21 generators, including voltage representation. This model is to be compared to two further simplified models assuming constant voltage.

Nordic13/1 model

By eliminating some generators in Norway and Finland, the 21 area model is reduced to the 13 area model shown in Figure 3.8. In this model voltage is omitted, i.e. assumed constant. Further the frequency is assumed to be the same throughout the entire system. This means that all rotating masses may be lumped to one single rotating mass corresponding to the total system inertia. The grid losses are calculated based on load flow and line resistances. The model is implemented in MATLAB SIMULINK (Matlab 2009) according to the description in the previous section.

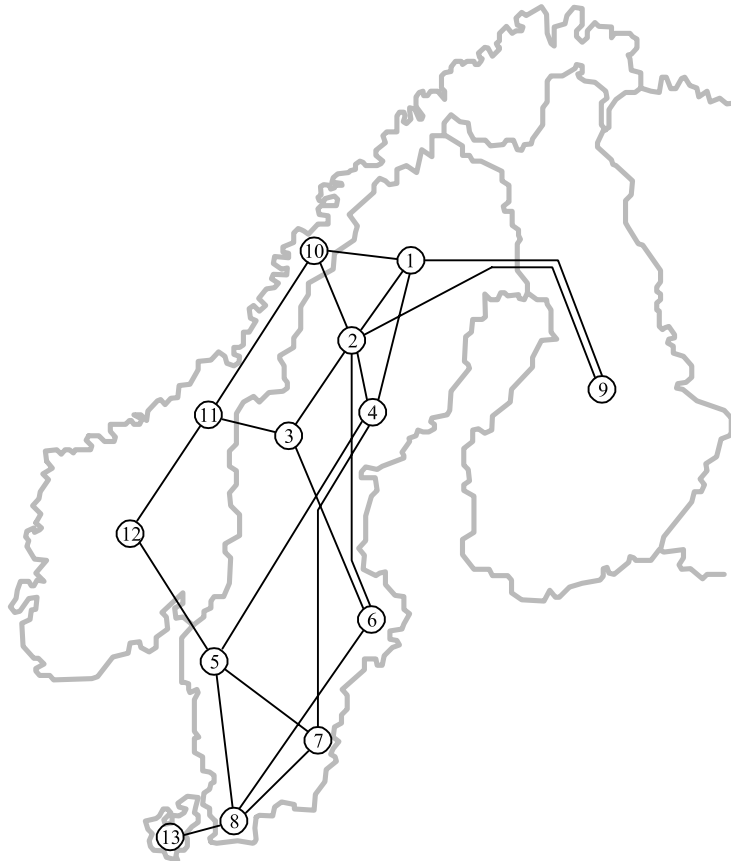

Figure 3.8 The 13 area Nordic model implemented in SIMULINK.

Nordic1/1 model

In the third and most simple model the previous 13 areas are lumped into one single area. This implies that transmission losses are now disregarded. Also this model is implemented in MATLAB SIMULINK.

Simulations

The three models described above are now compared to determine a suitable level of detail in a grid model for frequency dynamics studies.

Two versions of the Nordic21/21 model are used, one has 60% constant power / 40% constant impedance load and the other has no load voltage dependency. This yields the four cases in Table 3.4.

Table 3.4 Synthetic inertia and frequency support controller summary.

Model	Area	Mass	Simulation program	Comments
Nordic21/21	21	21	POWERFACTORY	with voltage
Nordic21/21	21	21	POWERFACTORY	without voltage
Nordic13/1	13	1	SIMULINK	without voltage
Nordic1/1	1	1	SIMULINK	without voltage without losses

Different Fault Locations

In the initial simulations different fault locations are compared. The simulated events are loss of 1 000 MW generation in area 1, 6 or 8, corresponding to 1.8% of total installed capacity. In the POWERFACTORY model the damping is poor and the frequency presented in Figure 3.9, Figure 3.10 and Figure 3.11 is from the generator with smallest amplitude of oscillations, located in the middle of Sweden. In the other two models there is only one frequency valid in the entire system.

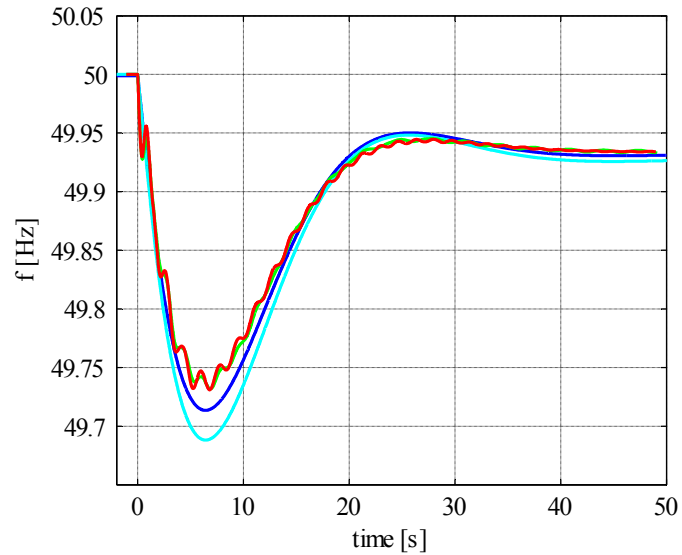

Figure 3.9 Frequency following loss of 1000 MW generation in area 1. Nordic21/21 model with voltage (green), Nordic21/21 model without voltage (red), Nordic13/1 model (blue), Nordic1/1 model (cyan).

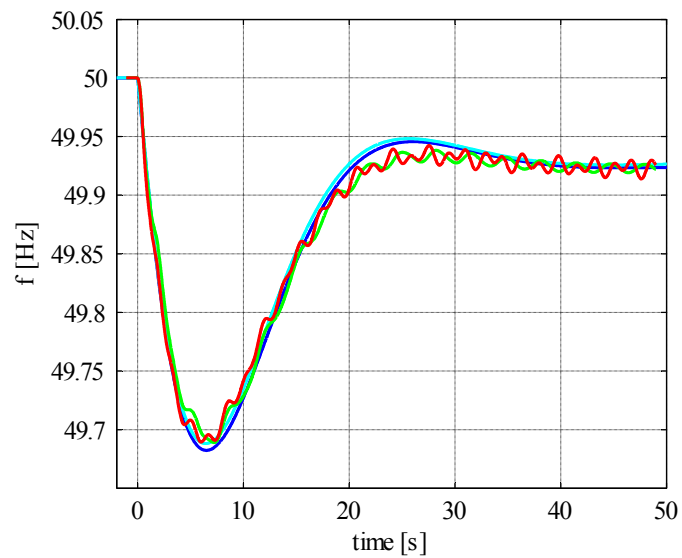

Figure 3.10 Frequency following loss of 1000 MW generation in area 6. Nordic21/21 model with voltage (green), Nordic21/21 model without voltage (red), Nordic13/1 model (blue), Nordic1/1 model (cyan).

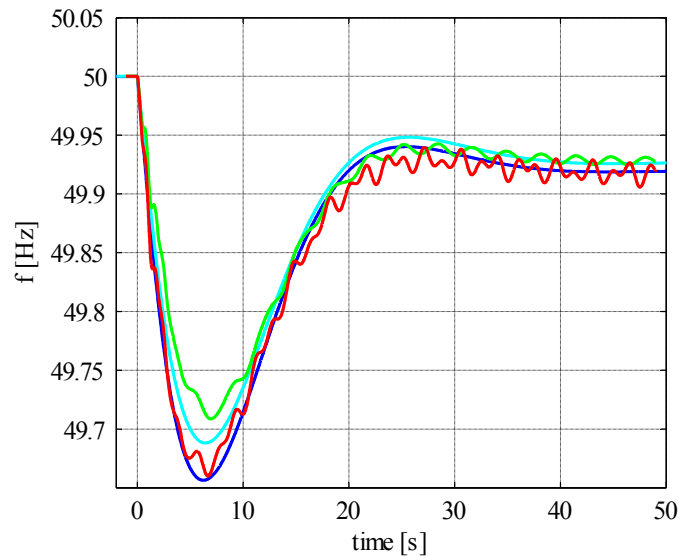

Figure 3.11 Frequency following loss of 1000 MW generation in area 8. Nordic21/21 model with voltage (green), Nordic21/21 model without voltage (red), Nordic13/1 model (blue), Nordic1/1 model (cyan).

The difference between Nordic13/1 and Nordic1/1 is due to the fact that the grid losses change as the load flow is changed. This change may influence the frequency in a positive as well as negative way depending on where in the system the disturbance occurs which can be seen when comparing a fault in areas 1 and 8.

Also when comparing the two versions of Nordic21/21, the difference is dependent on where the disturbance is applied. Especially for a fault in area 8 there is a clear difference between the two models. This is due to the fact that the voltage control capability is poor in this area, a voltage of 0.988 pu is achieved following the generation loss which leads to a reduced load power. It shall be noted that area 8 is an aggregation of a part of Southern Sweden and the load at this bus is quite high, 9 350 MW which equals 20% of the total load in the system. Hence a voltage deviation at this bus has great influence on the total load power and consequently on system frequency as well. In the real system it is not likely to have such high amount of load at one single bus and the amount of load subjected to low voltage is therefore expected to be

smaller and would not influence the total load to that extent. For a loss of generation in areas 1 and 6, introducing voltage dependency on the load makes no difference to the frequency behaviour.

For a fault in area 6 and 8 the Nordic13/1 model gives the same results as the Nordic21/21 model without voltage dependent load, except for the oscillations. When the fault is applied in area 1 there is a slight difference which may be due to the fact that the modelling of Norway and Finland is more simplified in the Nordic13/1 model.

Voltage and Frequency Dependent Load

It has already been shown that with proper voltage control the modelling of load voltage dependency has less importance. To further investigate the load modelling, comparative simulations are carried out. These show the effect of removing voltage dependency or frequency dependency. From Figure 3.12 it is obvious that the modelling of frequency dependency has far greater impact than the voltage dependency. This further verifies the statement that the voltage is of less importance when studying frequency dynamics.

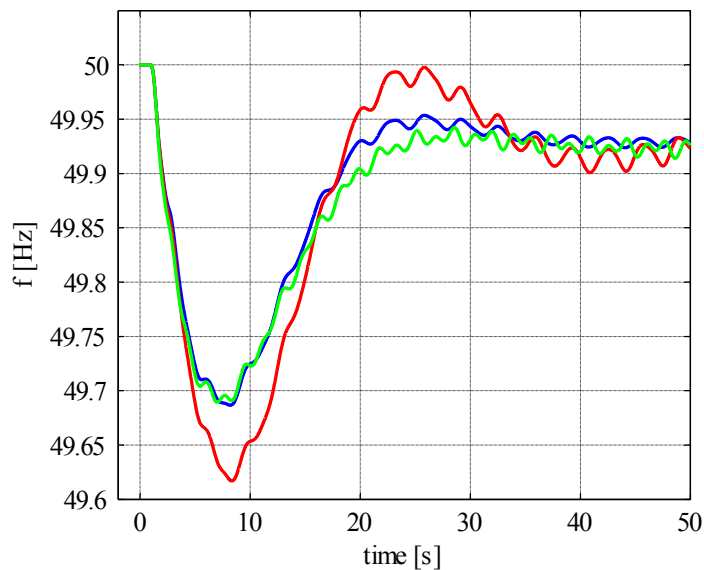

Figure 3.12 Influence of voltage and frequency dependent load in Nordic21/21 model. Loss of 1000 MW generation in area 6. V and f dependent load (blue), V dependent load (red), f dependent load (green)

3.5 Discussion

All the presented models are simplifications of the real power system and have their advantages and disadvantages.

The difference between minimum frequency in the 13-area and the 1-area model is about 30 mHz. This is about the same difference as achieved when introducing a hydro turbine damping coefficient of 0.5, as is sometimes used.

The most detailed model, which would normally be expected to be the most accurate one, has 20% of the total load connected at one bus which is unrealistic. A low voltage at this bus leads to a large change in total load power. If on the other hand voltage is assumed constant, as in the more simplified models, it is possible that the result is closer to reality. As a model is always made for a specific purpose the results from it may be misleading if the model is used when studying other phenomena. The model with 21 areas was originally designed for studying transmission capability, and later on damping, with focus on Norway. Hence Sweden, and especially the south of Sweden, are probably considered as not so important and are therefore heavily simplified.

When assuming constant voltage, there is still a difference between the results from the different fault locations. This is due to the fact that the transmission losses either increase or decrease depending on where generation is tripped relative to where control reserves are located.

The overall objective of this work is to study how frequency dynamics are affected when non-synchronous generation displaces synchronous generation. More specifically non-synchronous generation means wind power and the Nordic synchronous area is used as a case. For this purpose the 1-area model is considered the most appropriate of the analyzed models. This model is simple but still has explicit representation of the system inertia and turbine controllers, which are the most important system parameters when studying frequency dynamics. It is easy to study the behaviour of a system with high wind power penetration compared to a system with traditional generation. In most of the following simulations the simple Nordic1/1 model is used.

If a more detailed model is to be used for analysis of frequency dynamics, it is shown that the frequency dependence of the load is far more important than voltage dependence. The use of a model with explicit network representation is motivated mainly by focus on transmission losses or limitations. Such issues are outside the scope of this work.

Chapter 4

Induction Generator Frequency Response

Traditionally hydropower stations have been equipped with synchronous generators. Today when smaller stations are modernized a simple and reliable generator with a minimum of control equipment is attractive. Hence the old synchronous generator is often replaced by an induction generator. Due to this development the amount of induction generators in the power system is increasing and an important question is how this will affect the frequency dynamics of the system.

In (Lalor et al. 2005) the output power from synchronous generators, fixed speed and doubly fed induction generators is studied during a low-frequency event. It is shown that power system frequency dynamics will change as the type of production is changed from conventional power plants with synchronous generators to wind turbine generators with induction generators. But changing both generator and prime mover makes it unclear what is the cause of the change. The interesting question is therefore whether it is the type of generator or the prime mover that causes the difference in output power. In this chapter the influence of generator type only is studied.

4.1 Generic Test System

The influence of generator type on the frequency dynamics is determined by the ability of the generator to deliver power during a frequency disturbance. Therefore the power delivered by a synchronous and an induction generator, connected to a strong grid, is compared during a low-frequency event.

The test systems in the previous chapter were developed aiming at quantitative results for the Nordic synchronous area. Here it is more interesting to focus on general results that can be confirmed by laboratory

experiments. This motivates a different and more generic test system which is designed based on available laboratory equipment

The setup in Figure 4.1 with one synchronous generator, one induction generator and one DC motor, all on the same shaft, is used. The DC motor is fed by a power electronic converter controlled to have the same behaviour as a hydraulic turbine with constant gate opening, i.e. constant power. This is in order to avoid the influence of a frequency controller. With this setup it is possible to use either the synchronous or the induction generator and have exactly the same inertia. Both generators are rated 2 kW and the synchronous speed is 1500 rpm.

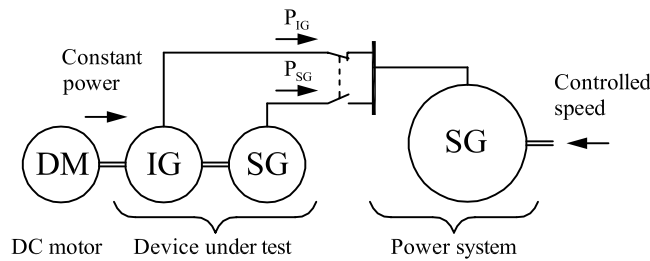

Figure 4.1 Experimental setup with a 2 kW induction generator and a 2 kVA synchronous generator electrically connected, one at a time, to a speed controlled 200 kVA synchronous generator.

In order to emulate a strong grid with variable frequency a 200 kVA synchronous generator, driven by a speed controlled DC motor, is used. The speed controller reference is a recording of a real frequency disturbance event in the Nordic power system with sudden loss of 1100 MW production.

The generator behaviour when subjected to a frequency disturbance is closely connected to the machine inertia as mentioned in (1.1). Formulating the same equation but replacing power with torque gives

$$J \frac{d\omega}{dt} = T_{mech} - T_{el} \quad (4.1)$$

with J the inertia, ω the speed, T_{mech} the mechanical torque and T_{el} the electrical torque. The laboratory machines have an inertia time constant of 0.7 s, i.e. about 3-5 times smaller than for a typical hydropower station (Kundur 1994). To still obtain a realistic response the frequency rate of

change is increased by dividing the time scale in the recorded frequency signal by 5.

4.2 Simulations

The test system is initially modelled in MATLAB SIMPOWERSYSTEMS and simulated using the same frequency variation recorded from the Nordic system as used for the 200 kVA synchronous generator in the lab. In Figure 4.2 the frequency is presented along with the power delivered by the synchronous and the induction generator respectively.

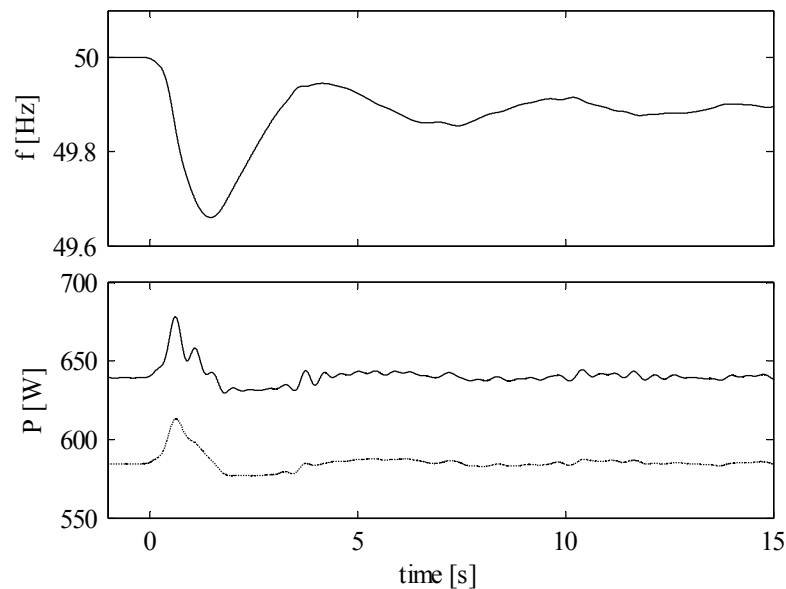

Figure 4.2 Simulated frequency disturbance. From top: frequency, generated power from synchronous generator and induction generator.

The power delivered from the two generators is almost equal with the main difference being the power oscillation of the synchronous generator related to its inherently low damping. Simulations made for different levels of loading, with and without voltage control show that these factors have no impact on the response to the frequency disturbance. The difference in output power level is due to different efficiency of the generators and the fact that the synchronous generator has a separate magnetizing circuit.

In Figure 4.3 the case with droop frequency control is simulated. The two

generators behave similarly also here. Due to the slow response of the hydro turbine the frequency controller initially makes no difference as compared to the constant power cases.

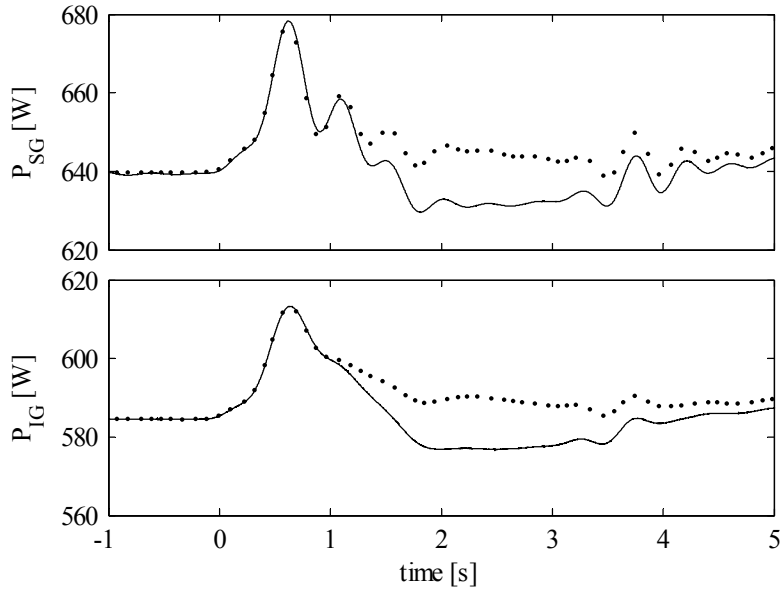

Figure 4.3 Simulated frequency disturbance: synchronous generator and induction generator output power with (dotted) and without (solid) frequency control.

4.3 Laboratory Test

To verify the simulations a laboratory test is made with the real machines that were modelled and simulated above. Due to noise in the measurements the instantaneous active power is filtered with a 2 Hz low-pass filter before being presented in Figure 4.4. The results are very close to the simulation results in Figure 4.3, with almost the same amount of power delivered by the two generators. It is clear that electrically, the two types of generators behave similarly if only the mechanical system is the same. To further verify this, the expression in (4.1) is rewritten.

$$P_{el} = P_{mech} - J\omega_{nom} \frac{d\omega}{dt} \quad (4.2)$$

The expected electric power P_{el} taken from the kinetic energy can then be calculated. An almost perfect correlation between calculated electrical power and measured power is shown in Figure 4.4. This implies that the output power during a frequency disturbance is practically affected only by the mechanical system and not by the type of generator.

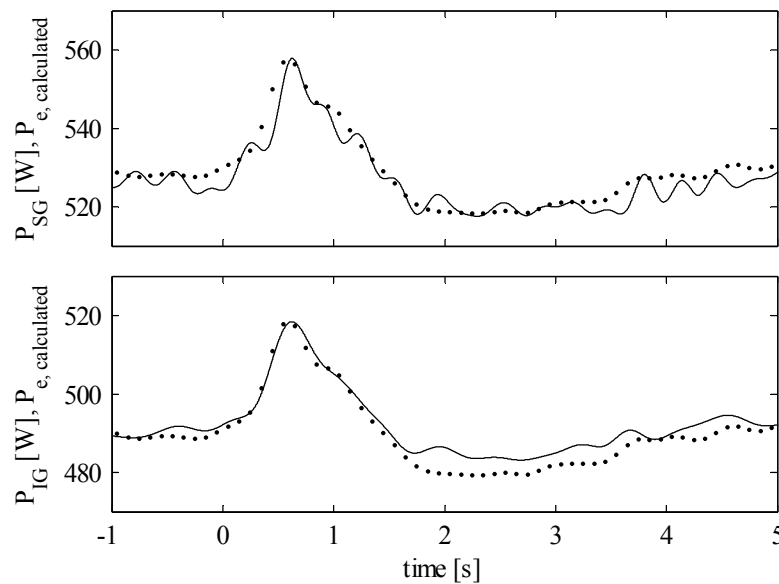

Figure 4.4 Laboratory measurements: synchronous generator and induction generator output power (solid). Electrical power calculated according to (4.2) (dotted).

4.4 Summary

In simulations and laboratory tests it is shown that the synchronous and induction generator capability of delivering power to the grid during a frequency disturbance is almost solely determined by the generator and turbine mechanical system, i.e. the amount of inertia and how the turbine is controlled. The induction generator has almost exactly the same behaviour as the synchronous generator during a frequency disturbance.

When hydropower plants are renovated also the mechanical characteristics such as the inertia may change. This of course affects the response to frequency disturbances, but is not directly related to the type of generator.

Chapter 5

Natural Inertia

In this chapter the required inertia in the Nordic system is investigated as well as the influence of frequency control response (MW/Hz) and load level.

Regarding frequency dynamics the question of increasing amount of wind power in the system is related to the resulting system inertia rather than the amount of installed wind power. Assuming the wind power does not contribute to the inertia, the only important question is whether or not the directly connected synchronous generators give a sufficient total inertia to maintain acceptable frequency dynamics. Hence the influence of inertia is studied without any connection to the level of wind power in this chapter.

5.1 Acceptable Frequency

Prior to any simulations the acceptable frequency range has to be defined. Acceptable frequency and frequency time derivative is directly related to settings of protections based on frequency.

Rate of Change of Frequency

Anti island protection of distributed generating units should identify island operation and trip the unit. This identification is typically indirect. In some countries Rate Of Change Of Frequency, ROCOF, protection has been commonly used to discriminate between power unbalance due to formation of a local island and loss of a remote unit. As the number of distributed generating sources increases, ROCOF protections have also been introduced in the Swedish system. As an example the setting of the wind power ROCOF protections used by the DNO Fortum in Sweden is 0.3 Hz/s with 1 s time delay. However ROCOF protections are sensitive and may easily lead to undesired tripping. In the ENTSO-E Draft Requirements for Grid Connection (ENTSO-E 2011), a generation unit shall not disconnect from

the grid due to rate of change of frequency up to 2 Hz/s and any rates of change of frequency above 2 Hz/s shall be withstood for at least 1.25 s without disconnection. This means that ROCOF protections with lower settings have to be removed soon.

Minimum Frequency

If the frequency drops below 49 Hz load is disconnected to reduce the frequency drop. Another important frequency level is 47.5 Hz where the nuclear power plants are disconnected by underfrequency protection (Nordel 2007).

When evaluating the following simulations 49.0 Hz and 2 Hz/s are regarded as limits not to be exceeded.

5.2 Nordic Power System Inertia

The rate of change of frequency following a disconnection of generation or load is mainly determined by the system inertia. Hence some realistic inertia values have to be determined.

To get a value for minimum inertia the minimum load of 30 000 MW is used. Assuming that this load is met by a combination of 15 000 MW hydropower, operated at 80% of its rated power, and 15 000 MW nuclear power, operated at 100%, the inertia is calculated. An inertia constant of 3 s for hydropower and 6 s for nuclear power plants is used in the calculations (CIGRÉ 1995) and a generator power factor of 0.9 is assumed. The assumption of hydropower operating at 80% of rated power is based on the fact that most hydropower stations have maximum efficiency at this operating point (Nordel 1997).

$$S_n H = S_{hydro} H_{hydro} + S_{steam} H_{steam} = \frac{15\,000\text{ MW}}{0.8 \cdot 0.9} \cdot 3\text{ s} + \frac{15\,000\text{ MW}}{0.9} \cdot 6\text{ s} = 162\,500\text{ MWs} \quad (5.1)$$

The maximum load in the Nordic system is about 60 000 MW which with the assumption of 30 000 MW hydropower and 30 000 MW nuclear power gives the maximum inertia of

$$S_n H = \frac{30\,000\text{ MW}}{0.8 \cdot 0.9} \cdot 3\text{ s} + \frac{30\,000\text{ MW}}{0.9} \cdot 6\text{ s} = 325\,000\text{ MWs} \quad (5.2)$$

In the simulations the inertia is allowed to vary between 100 000 and 300 000 MWs. This also includes the worst case with a load of 30 000 MW met by only hydropower, which gives an inertia of 125 000 MWs.

5.3 Simulations with Disturbance at 50.0 Hz

The following simulations are performed with the simplified 1-area model Nordic1/1 described in Chapter 2. To make the simulations as general as possible the amount of hydro and nuclear power is not mentioned. Instead the only things regarded here is system inertia and primary frequency control. These are the crucial parameters when studying frequency dynamics. As mentioned in Section 2.3 the dimensioning fault in the Nordic system is loss of a nuclear unit rated 1 400 MW. This is used as disturbance in the simulations. The inertia in the following simulations is referred to as predisturbance inertia. This inertia is decreased by $1\,400\text{ MW} \cdot 6\text{ s} = 8\,400\text{ MWs}$ when the largest nuclear unit is lost. It is assumed that the predisturbance frequency is 50.0 Hz, i.e. the entire normal operating reserve is available.

Different Inertia

The influence of varying system inertia is shown in Figure 5.1.

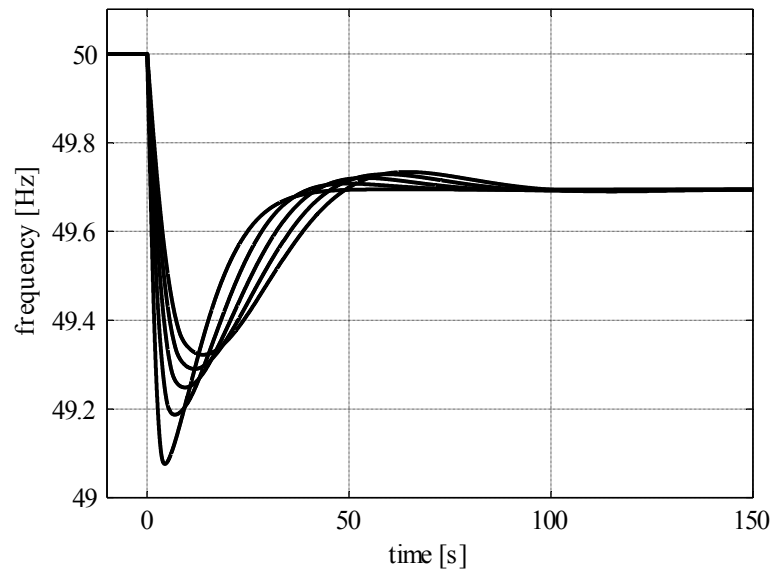

Figure 5.1 Frequency at loss of 1 400 MW production with different inertia. From bottom: 100 000, 150 000, 200 000, 250 000 and 300 000 MWs.

The primary control is selected to just fulfil the requirements, i.e. a normal operating reserve of 600 MW with 6 000 MW/Hz and a disturbance reserve of 1 200 MW with 3 000 MW/Hz. These are obtained by hydropower. The load is kept constant at 40 000 MW while the inertia is varied between 100 000 MWs and 300 000 MWs. As expected both df/dt and Δf are improved by increasing inertia.

Different Load Levels

In the previous simulations the load was kept constant but due to its frequency dependence the amount of load also affects the frequency dynamics. With the same primary control as before and an inertia of 200 000 MWs the load power is now varied. An increased amount of load at a constant inertia improves the frequency deviation while the initial df/dt is almost unchanged. The load power reduction due to frequency sensitivity close to 50 Hz is negligible and does not affect the initial df/dt .

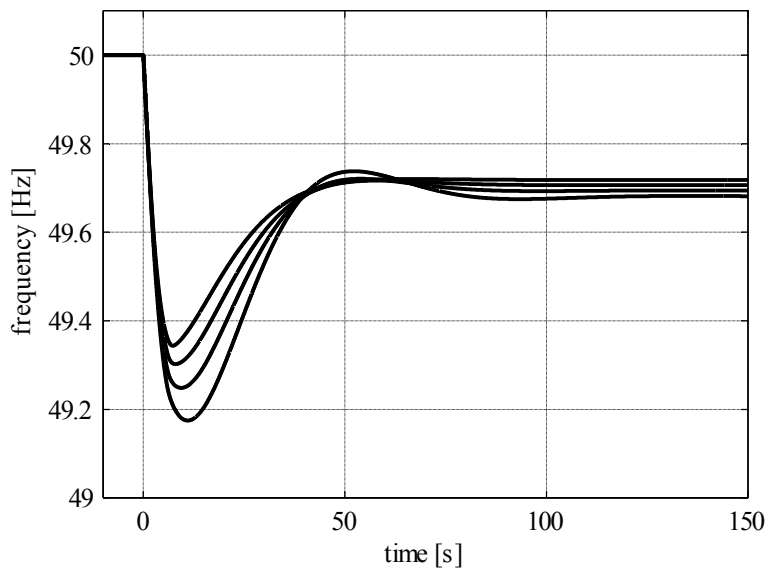

Figure 5.2 Frequency at loss of 1 400 MW production with different load power. From bottom: 30 000, 40 000, 50 000 and 60 000 MW load.

Fixed inertia means that the amount of synchronous generation on-line is unchanged and that the increased load is supplied by increased output of those that are on-line. Alternatively the increased load is supplied by non-

synchronous generation or increased import through HVDC.

Different Frequency Control Response

One important issue in connection to frequency dynamics is the turbine governor frequency response. To investigate this, a case with 40 000 MW load and 200 000 MWs inertia is selected. The frequency controlled normal operating reserve is kept at 600 MW while the disturbance reserve is increased from 1 200 MW to 4 800 MW. The governor droop setting is 0.04 in all cases which correspond to a frequency response variation between 3 000 MW/Hz and 12 000 MW/Hz, besides the normal operating reserve. Increase in reserve and gain reduces the frequency deviation while the slow turbine governors have no effect on the initial df/dt .

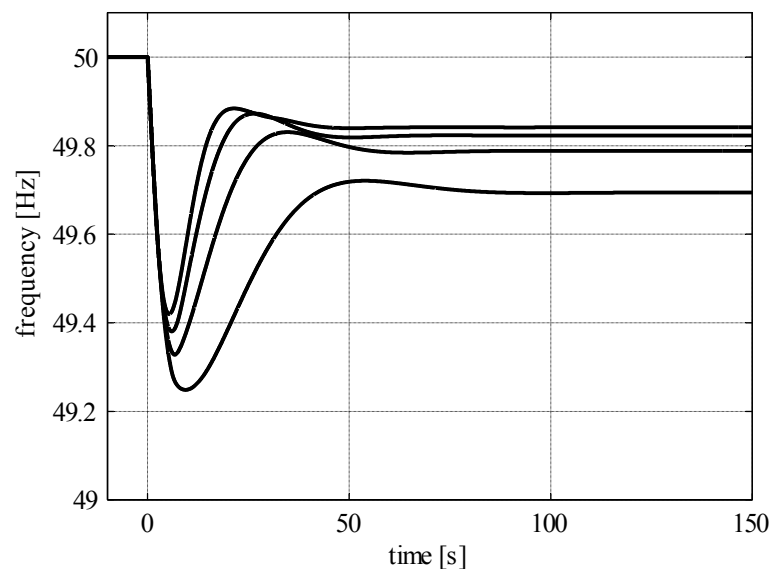

Figure 5.3 Frequency at loss of 1 400 MW production with different disturbance reserve. From top: 4 800, 3 600, 2 400 and 1 200 MW.

Summary of the Simulations

To get a better overview of the combination of influence of inertia, load, and frequency response the previous results, and some additional, are presented in a different and more general way in Figure 5.4 and Figure 5.5. The frequency time derivative is calculated 1 s after the fault and with a window length of 100 ms.

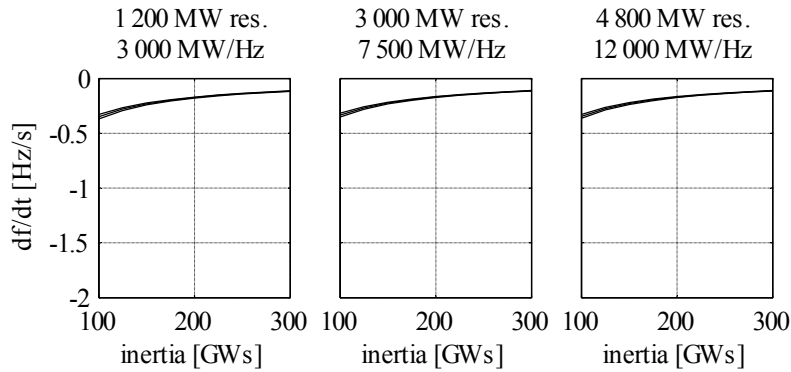

Figure 5.4 df/dt due to loss of 1 400 MW production with different reserve and load. From top 60 000, 45 000 and 30 000 MW load. Predisturbance frequency 50.0 Hz.

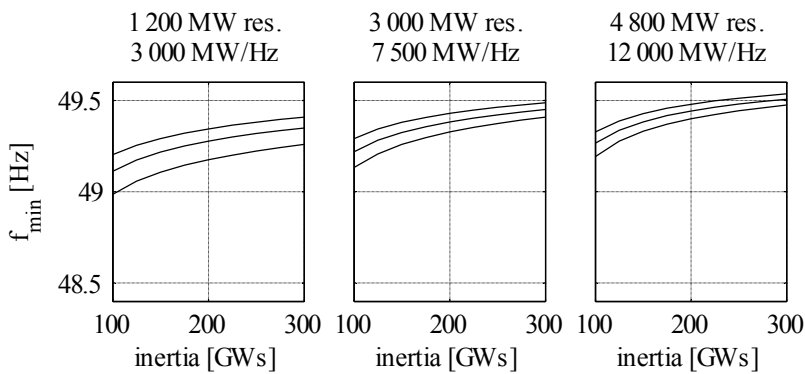

Figure 5.5 f_{\min} due to loss of 1 400 MW production with different reserve and load. From top 60 000, 45 000 and 30 000 MW load. Predisturbance frequency 50.0 Hz.

Due to the slow turbine governor response the initial df/dt is unaffected by increasing frequency response. It is mainly dependent on the inertia.

The frequency nadir is heavily influenced by the inertia but a reduced inertia can, to some extent, be compensated by increasing turbine governor frequency response. Also the amount of load has great influence on the minimum frequency.

For all cases in Figure 5.4 df/dt is well above the 2 Hz/s limit and the minimum necessary inertia is solely determined by the frequency deviation.

5.4 Simulations with Disturbance at 49.9 Hz

In the previous simulations it was assumed that the frequency was at 50.0 Hz when the disturbance occurred. However, also under normal circumstances the frequency varies between 49.9 and 50.1 Hz. A predisturbance frequency of 49.9 is thus a worse but very credible case. One reason for this is of course the lower initial frequency but what is more important is that the normal operating reserve is fully activated at 49.9 Hz giving 600 MW less reserve available than at 50.0 Hz. The same cases as above but with a predisturbance frequency of 49.9 Hz are shown in Figure 5.6.

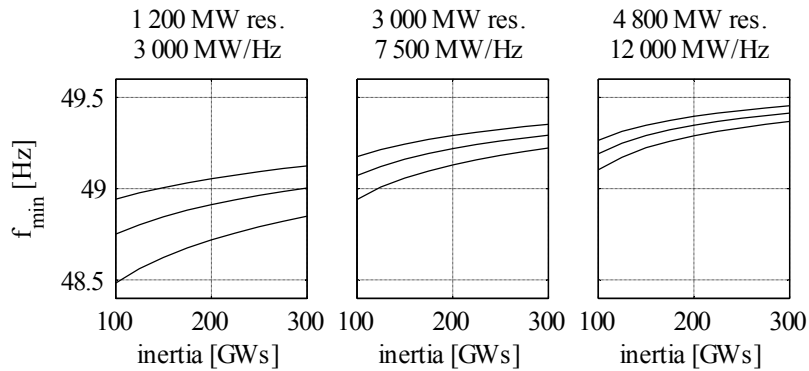

Figure 5.6 f_{\min} due to loss of 1 400 MW production with different reserve and load. From top 60 000, 45 000 and 30 000 MW load. Predisturbance frequency 49.9 Hz.

The frequency in the worst cases is now below the desired minimum level of 49.0 Hz. The requirements on 1 200 MW disturbance reserve and a minimum frequency response of 3 000 MW/Hz for the Nordic system ensures a stationary frequency above 49.5 Hz as intended but, as indicated in the left graph of Figure 5.6, does not necessarily imply an instantaneous frequency above 49.0 Hz. This suggests that already today a dimensioning fault occurring at 49.9 Hz can give a frequency drop to below 49.0 Hz if the disturbance reserve and the frequency response are at their minimum (but allowed) levels.

In (Nordel 2007) it is also stated that 50% of the disturbance reserve shall be activated within 5 s and 100% within 30 s. With the turbine governor settings of today this might be difficult to obtain in some cases. However frequency controlled system protections such as emergency power from

HVDC-links is activated beside the disturbance reserve in order to counteract a frequency drop. Such system protections are not included in the simulation model wherefore slightly more positive results are expected in the real system.

5.5 Discussion

The question of how much wind power the system can handle, regarding frequency dynamics, is a question of inertia rather than amount of wind power. The simulations in this chapter confirm the expectation that, as long as a minimum inertia is ensured, the system can handle any amount of wind power from the frequency dynamics point of view.

One assumption to be kept in mind is that these results are obtained with a model assuming constant voltage. However given the fact that modern wind turbines have voltage control capability and the fact that only part of the system load is subjected to a deviating voltage during the disturbance, makes the results still credible. If any change at all, the voltage dependency is expected to give slightly more positive results than those presented here.

It is demonstrated that a credible, but challenging case is when the dimensioning fault with loss of 1 400 MW nuclear generation occurs at 49.9 Hz with the disturbance reserve and the frequency response at their minimum allowed levels. Increasing these levels will improve the minimum frequency, but governor response speed is also an issue. In the Nordic system of today, where the disturbance reserve is mainly available from hydropower, governor response might in some situations not be fast enough. This is a consequence of reserve and frequency response nowadays being part of the market and therefore not so generously selected as before. The question of governor time constants in the Nordic system is currently discussed.

The focus of this work is influence of non-synchronous generation on frequency dynamics. While using 49.9 Hz as predisturbance frequency presents a more difficult and thus interesting case, it also represents an unclear situation where the proposed performance limits are not met by the current system without non-synchronous generation. To avoid mixing two problems, 50.0 Hz is used as predisturbance frequency in the simulations presented in the following chapters. Hence problems related to wind power are separated from possible problems related to non-ideal hydro governor parameters and current requirements on frequency control reserves. The choice of 50.0 Hz as predisturbance frequency does not affect the general conclusions regarding wind power, synthetic inertia and frequency support.

Chapter 6

Synthetic Inertia

In this chapter the idea behind synthetic inertia is explained and the control strategy is evaluated from the Nordic power system point of view. Problems related to synthetic inertia are also pointed out and some possible solutions are investigated.

6.1 df/dt -controller

Synthetic inertia requires some sort of energy storage to be able to temporarily increase output power. The concept is therefore applicable to wind turbines which have a reasonably large amount of kinetic energy stored in the rotor. The inertia constant is in the order of 2-6 s (Morren et al. 2006) which is comparable to traditional synchronous generation with various types of turbines and a resulting inertia constant in the range of 2-10 s (Kundur 1994). In a variable speed wind turbine, i.e. DFIG or FSC, there is no direct connection between rotor speed and electrical frequency. Hence no energy will be released from the rotor during a low frequency event and no positive effect on frequency is achieved. However with proper active control actions it is possible to temporarily increase the electrical output power in a critical situation and hence obtain a synthetic inertial response. As the aerodynamic power captured from the wind is usually maximized it can not be increased further. Instead the additional power has to be taken from the kinetic energy in the rotor, which causes the rotor speed to decrease. After the period of overproduction the output power has to be reduced to a value below available aerodynamic power in order to accelerate and restore the turbine speed to a value determined by the optimal speed control. The maximum period of overproduction is limited by the fact that the turbine must not stall, hence the minimum speed must not be reached. In a synchronous generator the rotor speed and the associated kinetic energy is restored together with the frequency, but also here the acceleration comes at the cost of temporarily

reduced electrical output.

The most obvious way of implementing synthetic inertia is to mimic the natural inertial response of a synchronous generator. This is achieved by adding an extra torque proportional to df/dt (Ekanayake et al. 2004). If using pu notation this torque is given by

$$T = 2H \frac{df}{dt} \quad (6.1)$$

which is added to the torque reference value obtained by the optimal speed control see Figure 6.1. If the gain K_1 is selected as $2H$ the output power will increase according to an inertia constant H , which should give the intended inertial response. The optimal speed controller then tries to maintain operation at maximum power by decreasing its torque reference. This counteracts the desired increase in output power.

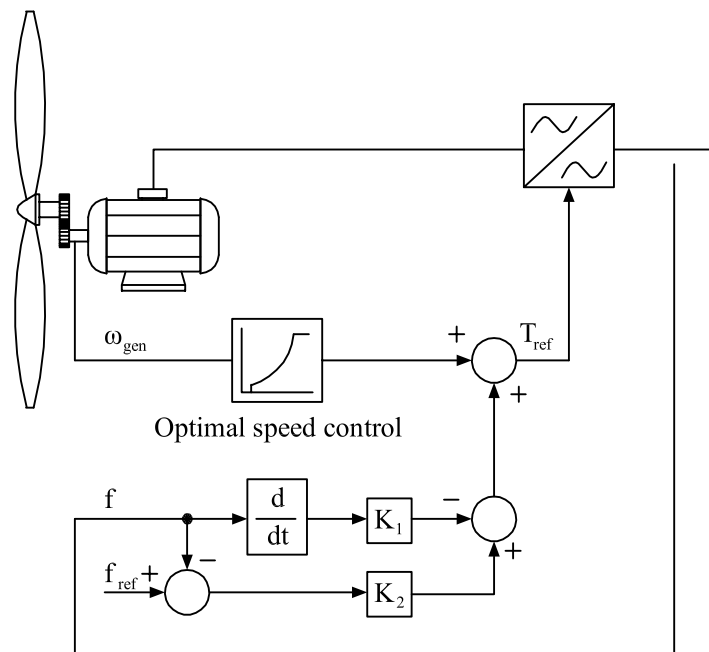

Figure 6.1 FSC wind turbine with synthetic inertia controller adding a term to the torque reference.

To cancel the influence from the optimal speed controller (which is undesired in this situation) and permit suboptimal operation during frequency deviations, the proportional term with gain K_2 is added (Ramtharan et al. 2007).

Another possibility is to hold the value from the optimal speed function constant when a frequency disturbance is detected (Loukarakis 2011). As the lower speed limit is reached, or a certain time has passed, operation is gradually shifted back to normal operation with an operation point determined by the optimal speed controller.

A direct differentiation of measured frequency as indicated in Figure 6.1 is not preferable since noise in the frequency signal is amplified. Hence filtering measured frequency is necessary (Lalor et al. 2005).

Another problem related to the df/dt -controller is the low frequency power oscillations present after a disturbance. These oscillations are difficult to filter out due to their low frequency and may cause problems when differentiating the frequency signal (Akbari et al. 2010).

In (Ullah et al. 2008) and (Tarnowski et al. 2009) the capability of a wind turbine to temporarily deliver additional power is investigated. A possible overproduction of 0.1-0.2 pu, for 10 s is indicated. These values are found by increasing the output power as fast as possible and maintaining that operating point until the lower speed limit is reached. Then the recovery period, with underproduction, starts to restore the turbine to the normal operating point.

When operating above rated wind speed, the full power available from the wind is not utilized. In this case it is possible to increase the aerodynamic input power by means of pitching the blades and hence avoid the speed reduction and recovery period. Of course all overproduction is limited by the turbine, generator and converter ratings.

The literature has much focus on the behaviour of a wind turbine or a wind farm. However the performance of synthetic inertia and frequency controllers is also dependent on the system it is connected to. Hence the entire system has to be considered, this is especially important in a system with high wind power penetration. Such a system is investigated in the following simulations.

Wind Turbine Model with Synthetic Inertia

In the following simulations the FSC wind turbine model briefly described in Chapter 3, and in detail in (Grunnet et al. 2010), is used. The original model

is extended with the inertia controller in Figure 6.2. The turbine has an inertia of $H=6.5$ s and the gain K_1 selected as $2H=13$ to utilize the kinetic energy in a way similar to a synchronous generator with $H=6.5$ s. K_2 is set to 5.

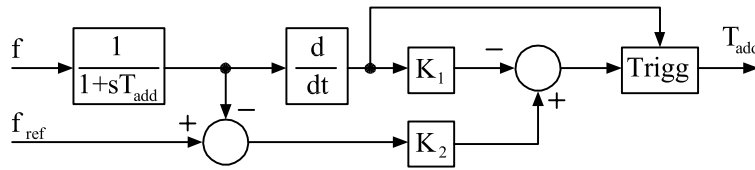

Figure 6.2 df/dt -controller.

Measured frequency is filtered with a 0.25 Hz low-pass filter. df/dt is calculated with a time window of 200 ms and is used to trigger the controller. The controller is activated as df/dt exceeds 0.05 Hz/s and remains active for 30 s. After 30 s the controller output is ramped down to zero during the next 60 s. The turbine operating point is then again determined by the optimal speed control and maximum power is extracted from the wind. It is necessary to ramp down the controller output due to the Δf term which does not reach zero as long as the frequency has a stationary error. The frequency will not be restored to its nominal value until the secondary frequency control is activated. In order to deliver maximum power it is preferable to quickly resume normal operation, with an operating point entirely determined by the speed curve. However a smooth transition to normal operation is also preferable to avoid unnecessary impact on the frequency. To avoid excessive stress on the turbine the output power is rate limited to 0.1 pu/s.

6.2 Study Case

Problems related to frequency dynamics are worst in low load situations with high wind power production due to less synchronized generation and low inertia. These are the situations where synthetic inertia may be most needed and are therefore the most important to investigate. With higher inertia the system is able to handle large amount of wind power anyway as shown in Chapter 4.

To study the controller performance with conditions valid for the Nordic synchronous area the single mass model Nordic1/1 described in Chapter 3 is used. A case with 30 000 MW load, considered as the worst case, is used. It is assumed that hydropower is used to meet the reserve and frequency response

requirements. This gives 18 000 MW synchronized hydropower, delivering 16 200 MW. In the initial case the rest of the load demand is met by 13 800 MW thermal power. The hydropower has an inertia of 54 000 MWs and the thermal power 82 800 MWs which gives a total system inertia of 136 800 MWs in the initial case. When thermal power is replaced by 15 000 MW wind power the inertia is reduced to 64 800 MWs. All values are summarized in Table 6.1.

Table 6.1 Study case parameters.

	Initial case	Wind power case
Load power	30 000 MW	30 000 MW
Hydropower	16 200 MW	16 200 MW
Thermal power	13 800 MW	1 800 MW
Installed wind power		15 000 MW
Wind power production		12 000 MW
Wind speed (rated value)		10.5 m/s (11.3 m/s)
Natural inertia	136 800 MWs	64 800 MWs
Normal op. reserve	600 MW, 6 000 MW/Hz	600 MW, 6 000 MW/Hz
Disturbance reserve	1 200 MW, 3 000 MW/Hz	1 200 MW, 3 000 MW/Hz

6.3 Simulation with df/dt -controller

To study the performance of the df/dt -controller the case with 30 000 MW load, described previously and summarized in Table 6.1, is used. Initially the load demand is met by hydro and thermal power. In the next case thermal power is replaced by 15 000 MW wind power without inertia control. The wind speed is 10.5 m/s giving a wind power production of 12 000 MW. In the last case the wind power is equipped with inertia control. The three cases are summarized in Figure 6.3 where frequency, generated hydropower, wind power and wind turbine rotor speed is shown for a loss of 1 400 MW thermal production. The first 40 s of Figure 6.3 is enlarged in Figure 6.4.

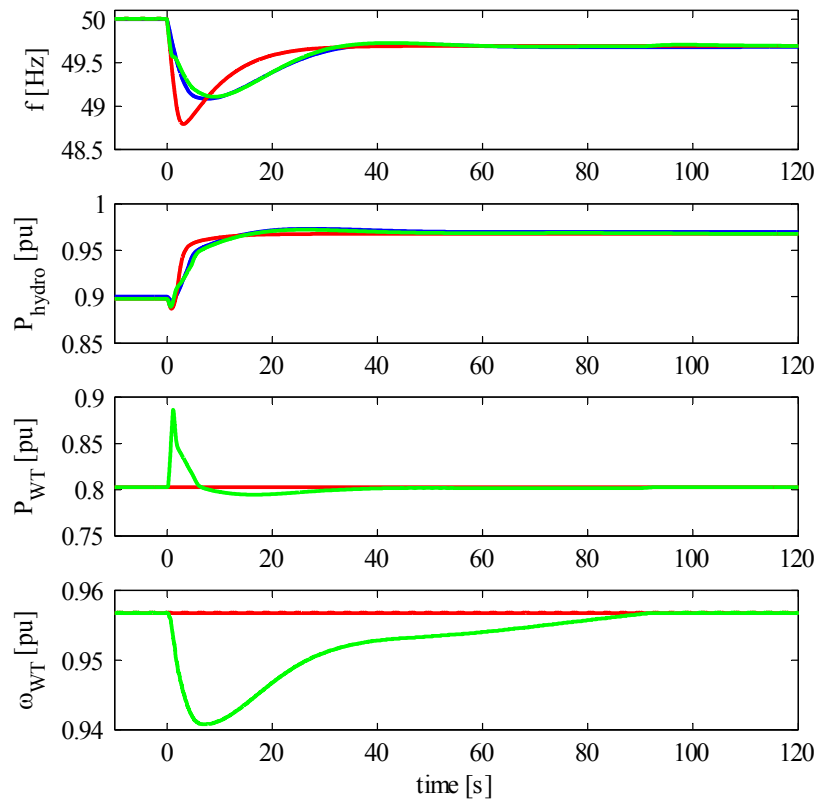

Figure 6.3 Hydro and Thermal power 136 800 MWs (blue), hydro and wind power without inertia control 64 800 MWs (red), hydro and wind power with df/dt -controller 64 800 MWs (green). Wind speed 10.5 m/s, wind power extracting maximum power from the wind.

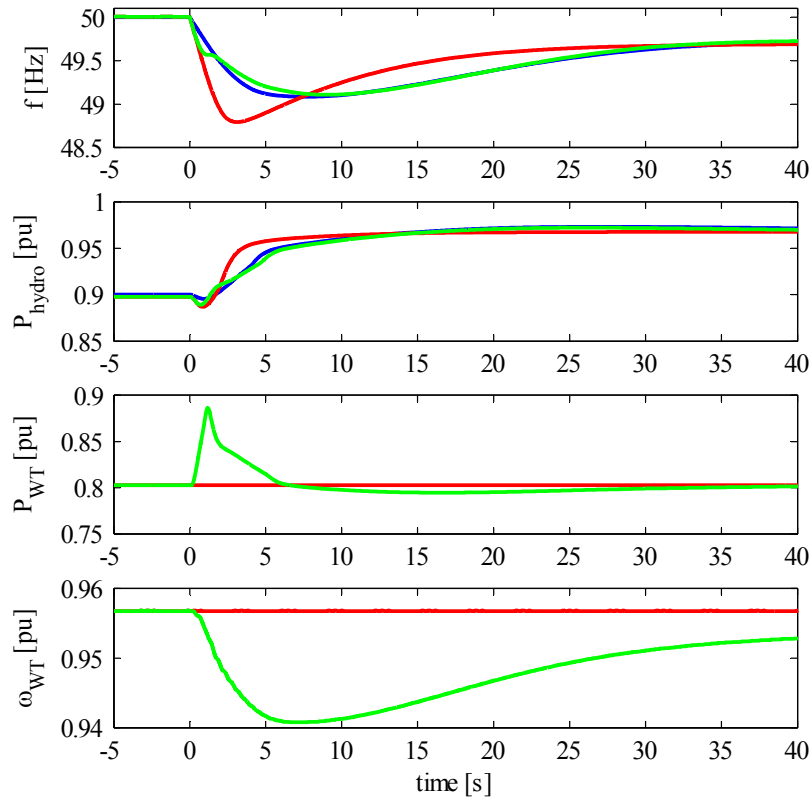

Figure 6.4 Hydro and Thermal power 136 800 MWs (blue), hydro and wind power without inertia control 64 800 MWs (red), hydro and wind power with df/dt -controller 64 800 MWs (green). Wind speed 10.5 m/s, wind power extracting maximum power from the wind.

When the system inertia is reduced df/dt is increased and the frequency nadir is below the desired limit of 49 Hz. With inertia control added to the wind turbines the frequency nadir is increased to a level comparable to the case without any wind power. The initial df/dt is not improved due to the delay in df/dt calculation and the trigger level in the controller but later on df/dt is in the same order as without wind power. The additional power is extracted from the kinetic energy stored in the rotating mass of the wind turbine and the turbine speed is reduced below optimum speed during the period of overproduction. As the frequency nadir is passed, and df/dt turns positive, the recovery period with wind turbine acceleration starts. The recovery period has to be chosen quite long to avoid an extra frequency dip when returning back

to normal operation.

This controller works well in combination with the existing hydro turbine governors and an inertial response close to the one of a synchronous generator is achieved. To avoid stalling wind turbines it is important to ensure that the minimum speed is never reached. According to several wind turbine manufacturers their turbines are capable of delivering an additional power of 0.1 pu, during 10 s, for all wind speeds. That is far more than the power needed in this case.

In the previous simulations the wind speed was 10.5 m/s and the turbines were operated to extract maximum power from the wind, which in that case equals 0.8 pu. In the following simulations the wind speed is increased to 15 m/s. At this wind speed it is possible to deliver rated power but the power reference is set to 0.8 pu, i.e. the turbine is operated below maximum available power. The results are shown in Figure 6.5 where the drop in turbine speed is now reduced by the pitch control increasing the aerodynamic power as additional power is demanded.

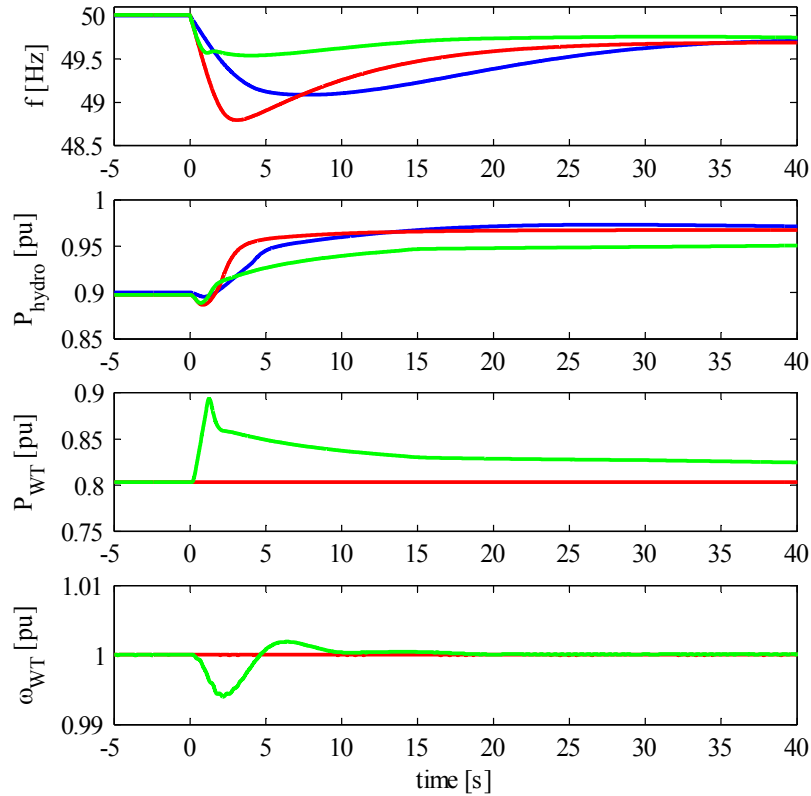

Figure 6.5 Hydro and Thermal power 136 800 MWs (blue), hydro and wind power without inertia control 64 800 MWs (red), hydro and wind power with df/dt -controller 64 800 MWs (green). Wind speed 15 m/s, wind power operated with 0.8 pu power reference.

Due to the Δf term the improvement of the inertia controller is larger than in the previous simulation. This term is used to compensate for change in operation point but as the available aerodynamic power is now enough to produce the ordered power, no such compensation is actually necessary for the purpose of supplying inertial response.

6.4 Response to Measured Frequency

In the previous simulations almost ideal conditions were assumed. Such conditions may not exist in a real system where frequency measurements contain noise and low frequency oscillations. Filtering or other additional signal processing may be considered to avoid that a df/dt controller translates

this frequency signal content into torque variations in the turbine mechanical system.

With just one mass in the simulation model previously used power oscillations were disregarded. To get a realistic view of such problems frequency measurements from the Nordic power system are used. The frequency is measured with Phasor Measurement Units (PMU). Measurements from year 2007-2010 have been studied and the event with the highest amplitude of oscillation is shown in Figure 6.6 where the calculated df/dt is also shown. The two measurements are from Lund in Southern Sweden and Tampere in Finland respectively. df/dt is calculated with a window length of 10 samples which equals 200 ms. High frequency noise in the time derivative is possible to filter out but removing the oscillation at about 0.45 Hz is more difficult.

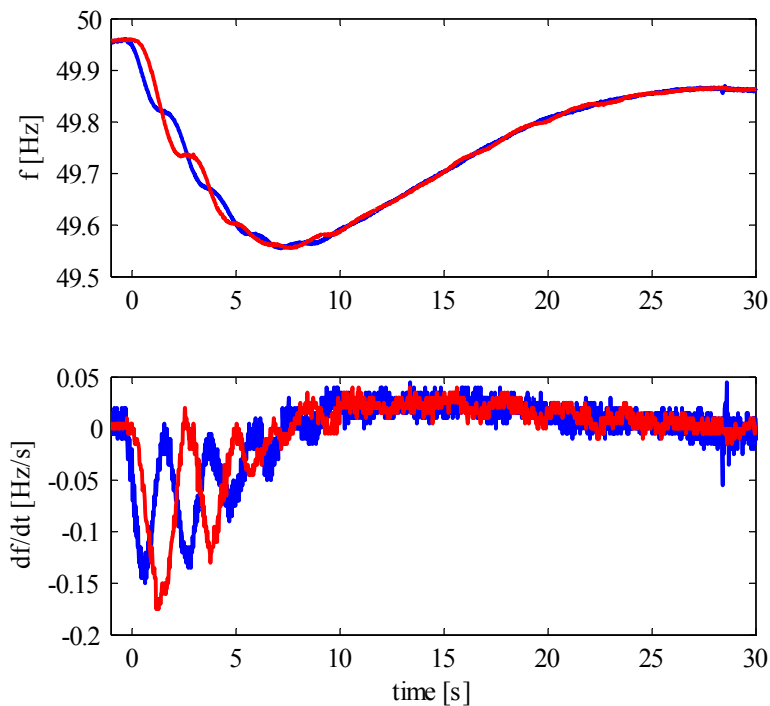

Figure 6.6 Measured frequency and calculated df/dt in Lund (blue) and Tampere (red) at 2008-04-13, 06-20-29.

A generator synchronously connected to the grid will naturally deliver or

absorb power according to the oscillations. A power electronic converter on the other hand does not normally react on the oscillations but when emulating inertia the df/dt feedback may result in an oscillating output power. This oscillating power is transferred to the turbine through the gearbox and may lead to wear on the mechanical system.

6.5 Synthetic Inertia Based on Directly Measured Frequency

To investigate the wind turbine behaviour in a multi-machine system with associated power oscillations the now classical two-area system in Figure 6.7 (Kundur 1994) is implemented in POWERFACTORY 14.0.

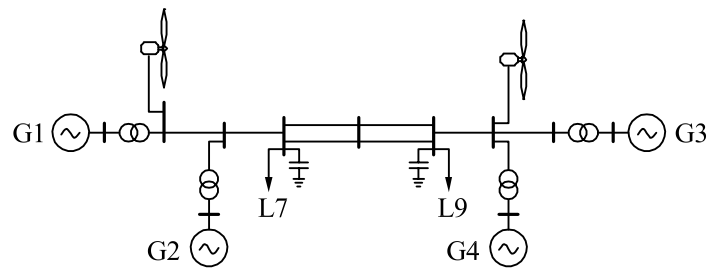

Figure 6.7 Two-area system.

All four generators are rated 900 MVA and are operating at about 700 MW each. The resulting system inertia is 21 600 MWs. Load L7 is 967 MW, L9 is 1 767 MW and the disturbance is a load increase of 200 MW at L7.

Simulations

Two extreme cases are to be investigated. In the first case the amount of wind power is very low. The wind power influence on the system frequency can then be neglected. In the high wind case the wind power can influence the system frequency and feedback in the measured frequency is obtained.

The wind turbine model is a standard library 2 MW DFIG model in POWERFACTORY where the converters are not modelled but the rotor side converter control is included. The standard model is modified to include the df/dt -controller. To increase the level of wind power a number of parallel machines are simply aggregated.

Low Wind Case

For the low wind case one 1.5 MW wind turbine is connected in parallel with generator G1 and another 1.5 MW turbine in parallel with G4. df/dt is calculated from measured frequency filtered with a 1 Hz first order low-pass filter. In Figure 6.8 an undesired oscillation in wind turbine output power is obvious.

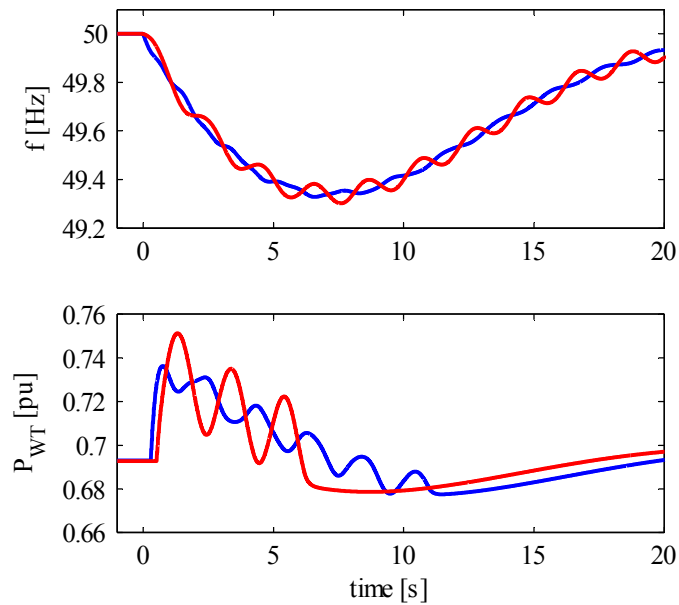

Figure 6.8 Low wind power, df/dt -controller with directly measured frequency filtered with 1 Hz low-pass filter. Top: frequency at G2 (blue) and G3 (red). Bottom: power from wind turbine connected at bus 1 (blue) and bus 4 (red).

High Wind Case

In the high wind case generator G1 and G4 have been disconnected and are entirely replaced by 2 x 700 MW wind power. The resulting frequency and wind turbine power are shown in Figure 6.9.

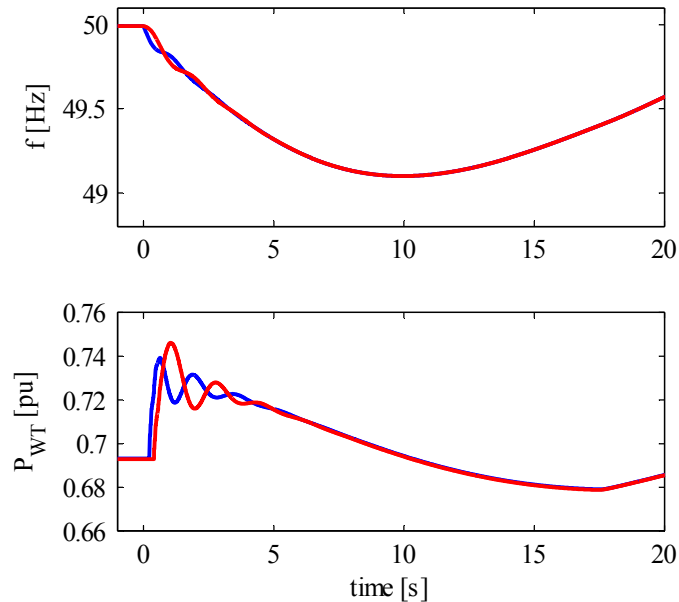

Figure 6.9 High wind power, df/dt -controller with directly measured frequency filtered with 1 Hz low-pass filter. Top: frequency at G2 (blue) and G3 (red). Bottom: power from wind turbine connected at bus 1 (blue) and bus 4 (red)

The wind power now has the ability to affect the system frequency. This does not only imply a good inertial response but also improves system damping. The wind turbines only have to withstand some periods of oscillations.

The df/dt -controller based on directly measured frequency thus shows acceptable performance in a high wind situation while the oscillations in the low load situation may seem unacceptable. In the next section an attempt to remove the oscillations in measured frequency, by means of estimating average frequency, is made.

6.6 Synthetic Inertia based on Average Frequency

The oscillation in Figure 6.6 is associated with power transferred back and forth between generators in the system. It can be seen that the oscillation in Lund has almost the opposite phase compared to that in Tampere. Hence a dominating oscillation mode is between Sweden and Finland. The oscillation power does not affect the total power in the system which is only determined by the amount of production and consumption. Hence it is possible to

calculate the system average frequency as an average of all generator frequencies. This technique is used in (Akbari et al. 2010). The drawback with this method is the involvement of communication. Further the different frequency measurements have to be scaled with the rotating mass in the subsystem where the measurement is made. This may become complicated as it is difficult to estimate the mass related to each measurement point. Instead it would be preferable to remove the oscillations in the frequency signal based on local measurements.

There are different possibilities for estimating system average frequency based on local measurements. One is the Kalman filter technique (Girgis et al. 1990). Another option is least square estimation, which is used here. The least square implementation can be implemented as a FIR-filter with fixed coefficients which gives a simple implementation without any demanding calculations.

It is assumed that frequency is obtained by a local measurement. Measured frequency (f_{meas}) is fitted to a second order polynomial in time and the parameters in this polynomial are estimated by means of the least-square method. The parameters to be estimated are denoted a , b and c in (6.2) where k is the sample index reflecting time and f is the frequency.

$$f = a + b \cdot k + c \cdot k^2 \quad (6.2)$$

For a window length of $2m+1$ samples, centred around zero, (6.2) may be rewritten as

$$\underbrace{\begin{bmatrix} f_m \\ \vdots \\ f_1 \\ f_0 \\ f_{-1} \\ \vdots \\ f_{-m} \end{bmatrix}}_F = \underbrace{\begin{bmatrix} 1 & m & m^2 \\ \vdots & \vdots & \vdots \\ 1 & 1 & 1^2 \\ 1 & 0 & 0 \\ 1 & -1 & (-1)^2 \\ \vdots & \vdots & \vdots \\ 1 & -m & (-m)^2 \end{bmatrix}}_\Phi \underbrace{\begin{bmatrix} a \\ b \\ c \end{bmatrix}}_C \quad (6.3)$$

The least-square estimation of a , b and c is given by

$$\begin{bmatrix} a \\ b \\ c \end{bmatrix} = (\Phi^T \Phi)^{-1} (\Phi^T) F \quad (6.4)$$

where

$$(\Phi^T \Phi)^{-1} (\Phi^T) \quad (6.5)$$

is a matrix with known elements which can be pre-calculated. To get compact notations matrix B is introduced.

$$B = (\Phi^T \Phi)^{-1} (\Phi^T) \quad (6.6)$$

B has three rows which are given the notation

$$B = \begin{bmatrix} B_1 \\ B_2 \\ B_3 \end{bmatrix} \quad (6.7)$$

The unknown parameters can then be calculated from

$$\begin{aligned} a &= B_1 \cdot F \\ b &= B_2 \cdot F \\ c &= B_3 \cdot F \end{aligned} \quad (6.8)$$

The notation $B(i, j)$ is used for the matrix element at row i and column j in the matrix B . The expression for the unknown parameter a is expanded

$$\begin{aligned} a &= B(1,1) \cdot f_m + B(1,2) \cdot f_{m-1} + \dots + B(1, m+1) \cdot f_0 + \\ &+ \dots + B(1, 2m+1) \cdot f_{-m} \end{aligned} \quad (6.9)$$

By using the shift operator defined as

$$f_k q^{-1} = f_{k-1} \quad (6.10)$$

the estimation can be written as a FIR-filter

$$a = H(q^{-1}) \cdot f_m \quad (6.11)$$

with

$$H(q^{-1}) = B(1,1) + B(1,2) \cdot q^{-1} + B(1,3) \cdot q^{-2} + \dots + B(1,m+1) \cdot q^{-m} + \dots + B(1,2m+1) \cdot q^{-2m} \quad (6.12)$$

It is concluded that the estimation of the parameters a , b , c can be done by implementing FIR-filters with the measured value f_m as input. After that a , b and c have been calculated the frequency in sample m is estimated as

$$f_m = a + b \cdot m + c \cdot m^2 \quad (6.13)$$

The solution to the least-square problem can be obtained by the FIR-filter in Figure 6.10, with coefficients according to

$$B_{tot} = B_1 + B_2 \cdot m + B_3 \cdot m^2 \quad (6.14)$$

These coefficients are fixed and the solution with a FIR-filter therefore eliminates the need for heavy calculations involving inverting and transposing matrices. As the average frequency, f_{mean} , is estimated the oscillation, i.e. deviation from average frequency, can also be determined by subtracting average frequency from the measured frequency.

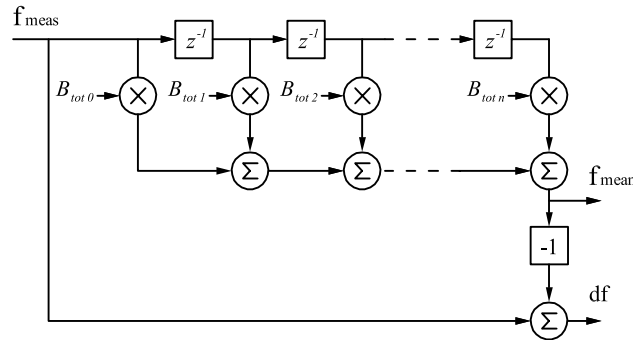

Figure 6.10 FIR-filter for average frequency and oscillation estimation.

The algorithm is implemented in MATLAB with a sample frequency of 50 Hz and $m=200$. In Figure 6.11 the algorithm is used for estimating system

average frequency from the previously presented Nordic measurements. Most of the oscillations are removed without introducing any significant delay and the average frequency from the two different locations are quite close to each other.

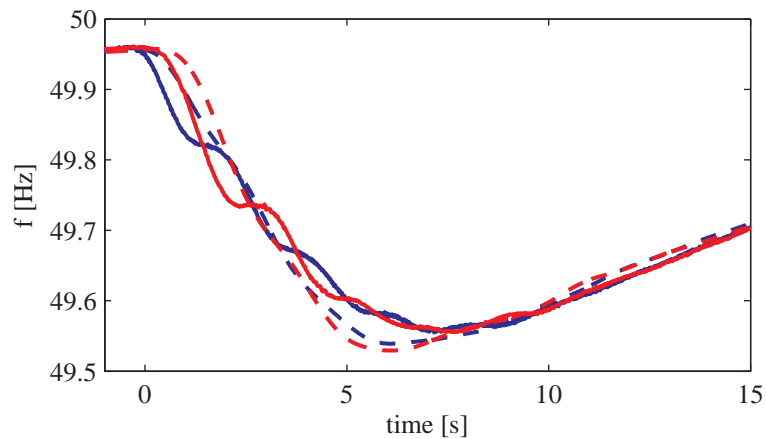

Figure 6.11 Measured frequency (solid) and estimated frequency (dashed) in Lund (blue) and Tampere (red) at 2008-04-13, 06-20-29.

A pretty good estimation of average frequency with local measurements is now possible but df/dt is of more interest for synthetic inertia. In Figure 6.12 df/dt for the measured and estimated Tampere frequency is shown. The oscillation is still present in the estimated df/dt but the amplitude of the oscillation is heavily reduced as compared to df/dt from the original signal in Figure 6.6. The time derivatives are calculated over 10 samples, i.e. 200 ms.

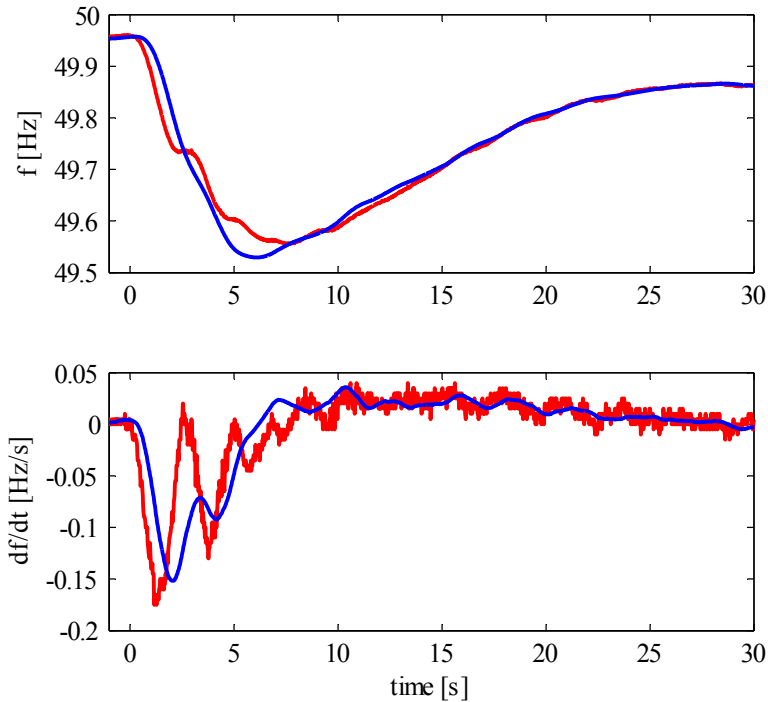

Figure 6.12 Measured (red) and estimated (blue) frequency, df/dt from measured frequency (red) and df/dt from average frequency (blue).

The phase shift from f_{meas} to df is positive for all interesting frequencies which implies that with a known oscillation frequency it is possible to compensate for both phase and gain error introduced by the estimation algorithm. Such compensation based on estimated oscillation frequency has been tested but was found not to give any better results. The algorithm is less sensitive to noise without the gain and phase compensation.

Simulation with Estimation Algorithm

The same two-area model as in Section 6.5 is used to evaluate the proposed estimation algorithm, starting with the low wind case followed by the high wind case.

Low Wind Case

When estimated average frequency is used, as in Figure 6.13, the output power is significantly smoother than in the case with directly measured

frequency, Figure 6.8, although a small amplitude oscillation is still present.

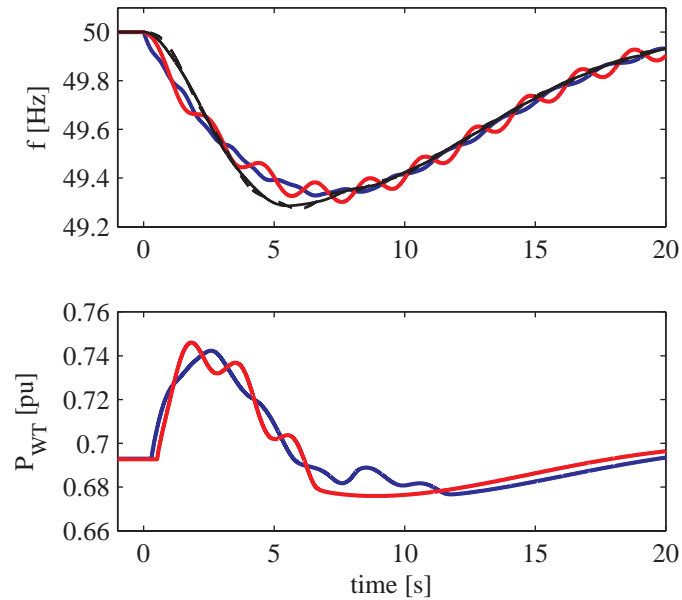

Figure 6.13 Low wind power, df/dt -controller with estimated average frequency. Top: frequency at G2 (blue) and G3 (red). Estimated frequency at wind turbine bus bars (black). Bottom: power from wind turbine connected at bus 1 (blue) and bus 4 (red).

In this low wind case the estimation algorithm is seen to improve the behaviour of the df/dt -controller.

High Wind Case

In the high wind case, Figure 6.14, the controller with average frequency estimation does not improve the system damping as the controller based on directly measured frequency in Figure 6.9. However the amplitude of the output power oscillation is lower than for the case with directly measured frequency.

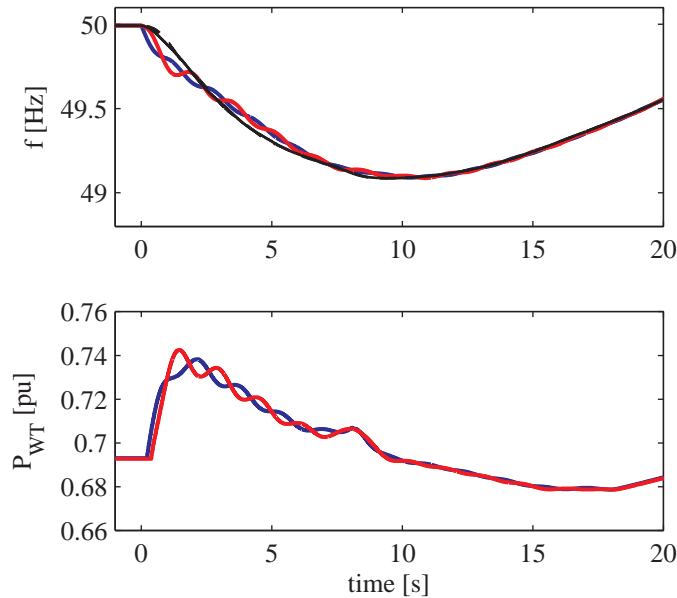

Figure 6.14 High wind power, df/dt -controller with estimated average frequency. Top: frequency at G2 (blue) and G3 (red). Estimated frequency at wind turbine bus bars (black). Bottom: power from wind turbine connected at bus 1 (blue) and bus 4 (red).

To confirm that the reduced inertia with G1 and G4 disconnected does not influence the conclusions regarding oscillations and damping the case with all generators synchronized but with G1 and G4 operating at no load has also been simulated. The conclusions above are found to be valid also with maintained inertia.

As the performance of the investigated controllers is highly dependent on the amount of wind power it is difficult to establish when to use which signal for the df/dt calculation. In the next section the possibility with heavier filtering of measured frequency instead of average frequency estimation is investigated.

6.7 Synthetic Inertia based on Low-pass Filtered Frequency

The measured frequency was previously filtered with a 1 Hz first order low-pass filter. To evaluate the possibility to use heavier filtering prior to the df/dt calculation, the high wind scenario is simulated once again, this time

with a 0.05 Hz filter on frequency. The results are shown in Figure 6.15.

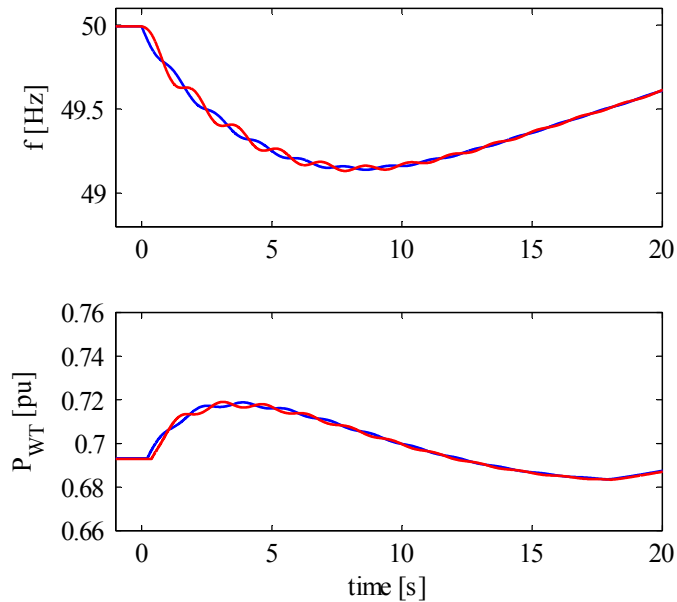

Figure 6.15 High wind power, df/dt from measured frequency filtered with 0.05 Hz low-pass filter (same scenario as Figure 6.9). Top: frequency at G2 (blue) and G3 (red). Bottom: power from wind turbine connected at bus 1 (blue) and bus 4 (red)

The oscillations the wind turbine have to withstand are now of considerably lower amplitude. However the damping is somewhat lower than before. Despite the slower response due to increased filtering the wind power still performs well and contributes to improve the frequency nadir.

In Figure 6.16 the df/dt calculation based on a 0.05 Hz filtered frequency is applied on the real Nordic frequency measurement previously used. The oscillations are rather effectively damped by the filter but at the same time df/dt is reduced.

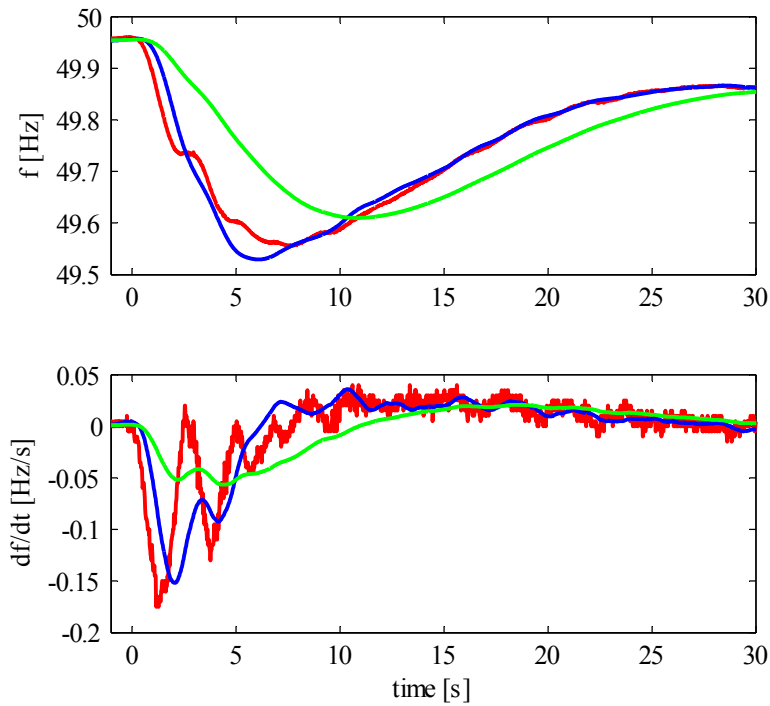

Figure 6.16 From top: Measured (red), estimated (blue) and 0.05 Hz filtered (green) frequency, df/dt from measured frequency (red), df/dt from average frequency (blue) and df/dt from filtered frequency (green).

To see the influence of heavier filtering the simple Nordic 1/1 model implemented in SIMULINK is used once again. In Figure 6.17 and Figure 6.18 the behaviour with 0.1 Hz and 0.05 Hz filter prior to df/dt calculation are presented.

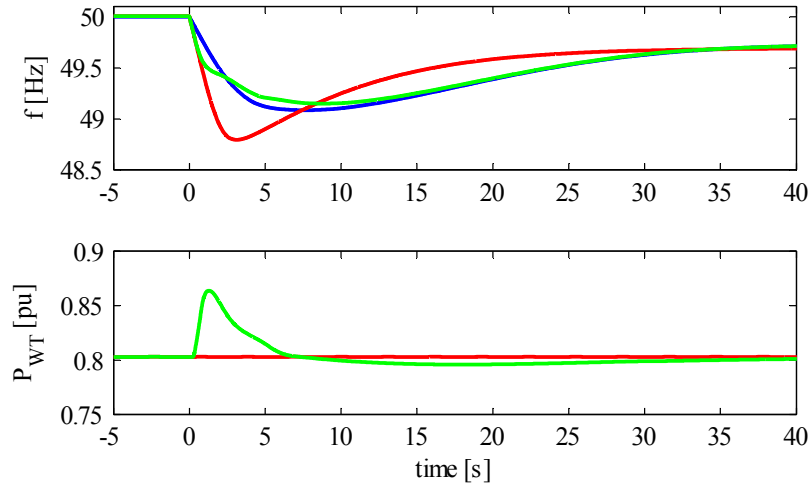

Figure 6.17 Hydro and Thermal power 136 800 MWs (blue), hydro and wind power without inertia control 64 800 MWs (red), hydro and wind power with df/dt -controller 64 800 MWs (green). df/dt calculated from measured frequency filtered with 0.1 Hz low-pass filter.

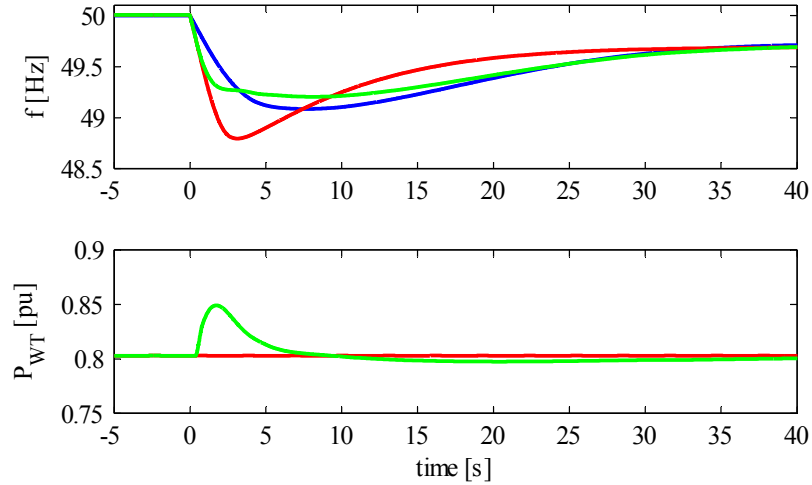

Figure 6.18 Hydro and Thermal power 136 800 MWs (blue), hydro and wind power without inertia control 64 800 MWs (red), hydro and wind power with df/dt -controller 64 800 MWs (green). df/dt calculated from measured frequency filtered with 0.05 Hz low-pass filter.

When comparing Figure 6.17 and Figure 6.18 to Figure 6.4, which shows the same case but with 1 Hz filter instead, it is clear that the 0.1 and 0.05 Hz filters do not have any negative effect on the controller. If the initial df/dt is disregarded the increased filtering actually improves the frequency and the frequency nadir is higher. This is due to the fact that the high initial df/dt gives a fast and high response of the hydropower turbine governors which is preferable in order to be well prepared for the wind power recovery period. The temporarily high df/dt is no problem since it is around 0.5 Hz/s which leaves a good margin to the 2 Hz/s limit.

Sensitivity Analysis

It has now been shown that a df/dt controller with a 0.05 Hz low-pass filter can improve the frequency dynamics at a loss of 1 400 MW thermal generation. However the loss of generation can of course be considerably lower and still trigger the synthetic inertia controller. In such a case it is important to make sure that the inertia control frequency response is not larger than the lost production. This is investigated in the next simulations. Further the behavior at different wind speeds is investigated.

Varying Disturbance

In Figure 6.19 the amount of disconnected generation is varied and both the cases with and without wind power are shown. Measured frequency is filtered with 0.05 Hz. The controller handles loss of 400 MW, 900 MW and 1 400 MW satisfactorily and improves the situation compared to the situation without wind power in all cases.

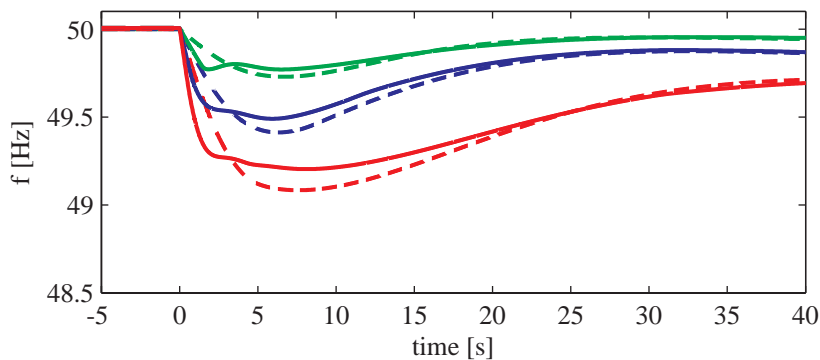

Figure 6.19 df/dt -controller with 0.05 Hz filter on measured frequency. Loss of 400 MW (green), 900 MW (blue) and 1 400 MW (red) generation. Without wind power (dashed), with controlled wind power (solid).

Varying Wind Speed

In Figure 6.20 the wind speed varies which gives an operating point of 0.2, 0.5 and 0.8 pu for the wind power. The load is 30 000 MW in all simulations and hydropower is kept constant to have equal frequency response while the thermal power is adjusted according to the wind power production. All these situations are well handled by the controller.

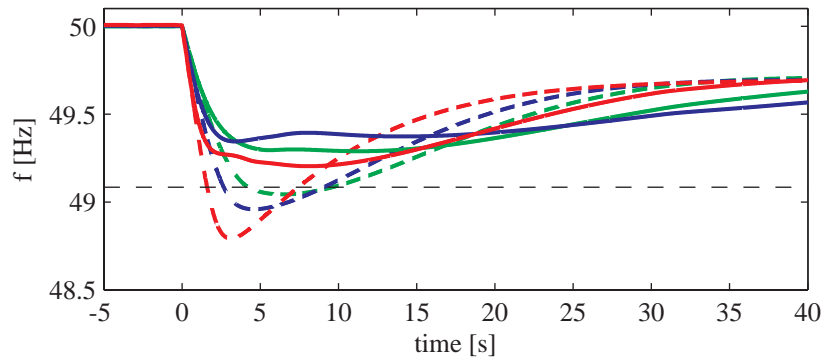

Figure 6.20 df/dt -controller with 0.05 Hz filter on measured frequency. Loss of 1 400 MW generation with uncontrolled (dashed) and controlled wind power (solid). 15 000 MW installed wind power producing 0.8 pu (red), 0.5 pu (blue) and 0.2 pu (green). Black dashed line indicates lowest frequency without wind power.

Gain Proportional to Operation Point

Since the reduction in system inertia is proportional to wind power production rather than the wind power rating the controller in the previous simulation is unnecessarily powerful at lower wind speeds. In Figure 6.21 the inertia controller gain K_1 and K_2 are made proportional to the current operating point. When operating at 1 pu the value of K_1 and K_2 are selected as previously, i.e. $K_1=2H=13$ and $K_2=5$.

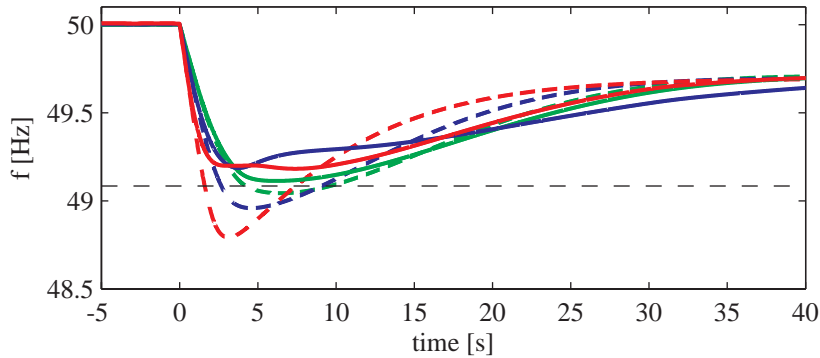

Figure 6.21 df/dt -controller with 0.05 Hz filter on measured frequency and with controller gain proportional to wind power production. Loss of 1 400 MW generation with uncontrolled (dashed) and controlled wind power (solid). 15 000 MW installed wind power producing 0.8 pu (red), 0.5 pu (blue) and 0.2 pu (green). Black dashed line indicates lowest frequency without wind power.

An operating point dependent gain gives a more uniform behaviour as the wind power production varies due to varying wind speed.

6.8 Summary

By controlling the active power according to df/dt it is possible to obtain a synthetic inertial response similar to the natural inertial response of synchronous generators. With df/dt calculated from a slightly filtered frequency, e.g. 1 Hz low-pass filter, the wind turbines act on power system oscillations and can actually improve the damping of these oscillations. However the turbines have to withstand the first periods of oscillation.

With low level of wind power in the system the influence from the wind power is not strong enough to damp the oscillations. Instead the oscillations are reflected in wind turbine output power. In that case it is preferable to disregard the oscillations in measured frequency. If the measured frequency is filtered with a 0.05 Hz low-pass filter prior to differentiating, the output power oscillation is almost eliminated. In spite of the delayed and reduced output power peak the frequency nadir is actually improved with heavier filtering. This shows that fast and high additional power does not necessarily give better frequency performance. In combination with the already existing turbine governors the decreased and delayed power increase is preferable.

An estimation algorithm for average frequency was also tested and a pretty good estimation of average system was achieved. However in combination with the synthetic inertia controller the estimation algorithm does not imply any improvement as compared to the 0.05 Hz filter.

The choice of controller input signal is depending on what to prioritize, system damping or a minimum of mechanical wear of the wind turbines. If system damping has the highest priority a less filtered signal is preferable but from the wind turbine point of view the heavier filtering is preferable. To further complicate the choice of controller the best option is dependent on the system and the level of wind power.

In the next chapter some possible alternatives to the df/dt -controller are investigated.

Chapter 7

Frequency Support

In the previous chapter the synthetic inertia controller, df/dt -controller, was investigated. It was observed that it responds to low frequency power oscillations present in the system after a disturbance. In this chapter the Δf -controller is used for improving the frequency following a major loss of generation. As already mentioned in Chapter 1, a Δf -controller can only improve the frequency nadir, not the initial df/dt . However as shown in Chapter 5 it is far more important to minimize frequency deviation than initial df/dt which is within acceptable limits also without any control.

After a short description of the Δf -controller, a controller similar to what manufacturers offer is simulated for the Nordic power system with high level of wind power. Then an attempt is made to define a general frequency support controller adapted to the Nordic conditions. Finally the use of wind power as traditional droop-based frequency control is investigated.

7.1 Introduction to Frequency Support

In (Morren et al. 2006) a control method where the additional power is proportional to frequency deviation is presented and compared to the df/dt -controller. It is concluded that the Δf -controller has some advantages over the df/dt controller due to better performance and lower mechanical stress on the turbine.

In (Wachtel et al. 2009) a Δf -controller, tested in an ENERCON wind turbine, is described. As the frequency falls below the deadband in Figure 7.1 the active power is increased in proportion to frequency deviation until fully activated when the controlband limit is reached. The maximum power increase of 0.05 pu is available for maximum 9 s. Then the additional power is ramped down to zero during 1 s.

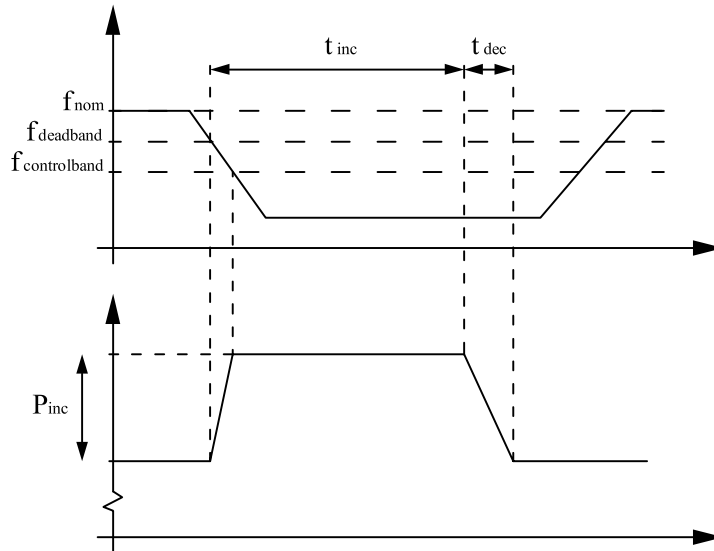

Figure 7.1 Δf -controller with maximum power increase P_{inc} (Marques 2011).

There are two options for calculating the resulting output power reference. The first is to calculate P_{ref} as the sum of P_{inc} and the power ordered by the optimal speed controller, P_{order} . This is illustrated to the left in Figure 7.2. The other option, to the right in Figure 7.2, is to add P_{inc} to the predisturbance value from the speed controller. In this way the decrease in rotational speed is excluded from the controller and the output power is constant during the period of overproduction. The total released energy is larger in this case and the rotor speed is further decreased as compared to the first controller, consequently the time for recovery is prolonged.

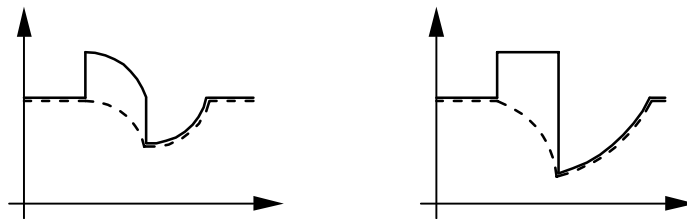

Figure 7.2 Left: P_{ref} (solid) depending on P_{order} (dashed). Right: P_{ref} constant (Wachtel et al. 2009).

Field tests on a 2 MW ENERCON wind turbine have shown that a 0.1 pu power increase for 10 s is possible provided that the turbine is operating above 0.04 pu.

Another controller for frequency support is the bang-bang controller proposed by Siemens (Knüppel et al. 2011). As the frequency falls below a certain level a predefined power increase is ramped up. If the maximum time for overproduction is reached, or the frequency recovers above the recovery threshold, the additional power is ramped down either with a fixed ramp rate or according to a droop function. In (Knüppel et al. 2011) simulations with a power increase of 5% or 10% during about 10 s is presented. It is also shown that the maximum overproduction is dependent on the wind speed.

(Wachtel et al 2009) and (Knüppel et al. 2011) have shown that ENERCON and Siemens respectively have turbines capable of delivering additional power, extracted from the kinetic energy, during a low frequency event. However it is unclear how their control methods will interplay with the rest of the power system and turbine governors. No results from a system with frequency feedback are presented.

In (Brisebois et al. 2011) an investigation of inertia emulation, made by Hydro Québec, is presented. It is found that a controller defined with power increase, power decrease and time for these actions, Figure 7.3, is sufficient for the Hydro Québec system. For the test system with 2 000 MW wind power and 13 500 MW load the following parameters are recommended. Maximum power increase: 6% for a minimum of 10 s, transition to underproduction 3.5 s and 20% power reduction during the recovery period. The power increase and decrease is in percent of predisturbance power.

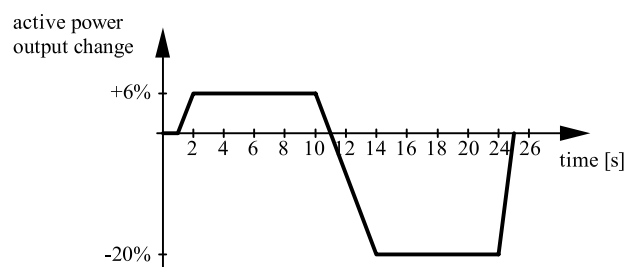

Figure 7.3 Active power contribution according to (Brisebois et al. 2011).

Wind turbine manufacturers normally show frequency response from their turbines for a frequency that is not affected by the turbine itself. However in

a system with high level of wind power the wind power affects the system frequency which is fed back to the controller. Hence the entire system has to be considered. In the next section the influence of a large amount of Δf -controlled wind power on the Nordic power system is studied.

7.2 Simulating Impact of Controller on System Frequency

The controller described here is close to the one used by ENERCON which seems representative for several manufacturers since differences are small. The controller model is designed to be as close as possible to what wind turbine manufacturers offer, however due to limited information minor discrepancies may exist.

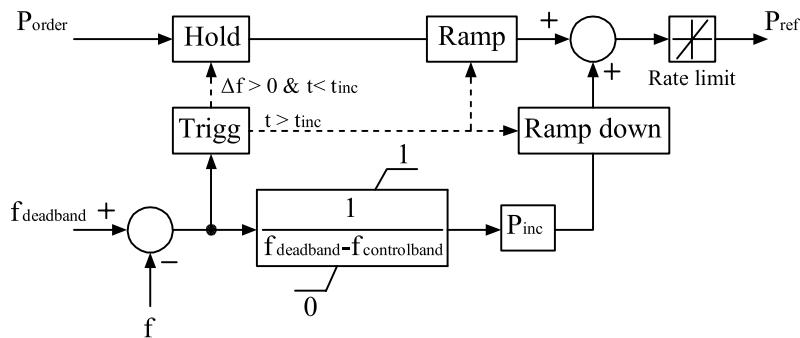

Figure 7.4 Δf -controller.

In the following simulation the power increase and its duration are adapted from (Wachtel et al. 2009), all controller parameters are summarized in Table 7.1.

Table 7.1 Controller parameters.

P_{inc}	0.05 pu
$f_{deadband}$	49.9 Hz
$f_{controlband}$	49.5 Hz
t_{inc}	9 s
t_{dec}	1 s
$P_{rate\ limit}$	0.1 pu/s

The test system is the Nordic1/1 single mass model, described in Section 3.4.

The case with 30 000 MW load and 15 000 MW wind power producing maximum power, i.e. 12 000 MW, is the same as when evaluating the df/dt -controller, see Section 6.2. The simulated disturbance is loss of 1 400 MW thermal production.

As the frequency falls below the deadband the controller is triggered and the additional power $P_{inc}=0.05$ is added to the predisturbance power reference, Figure 7.5.

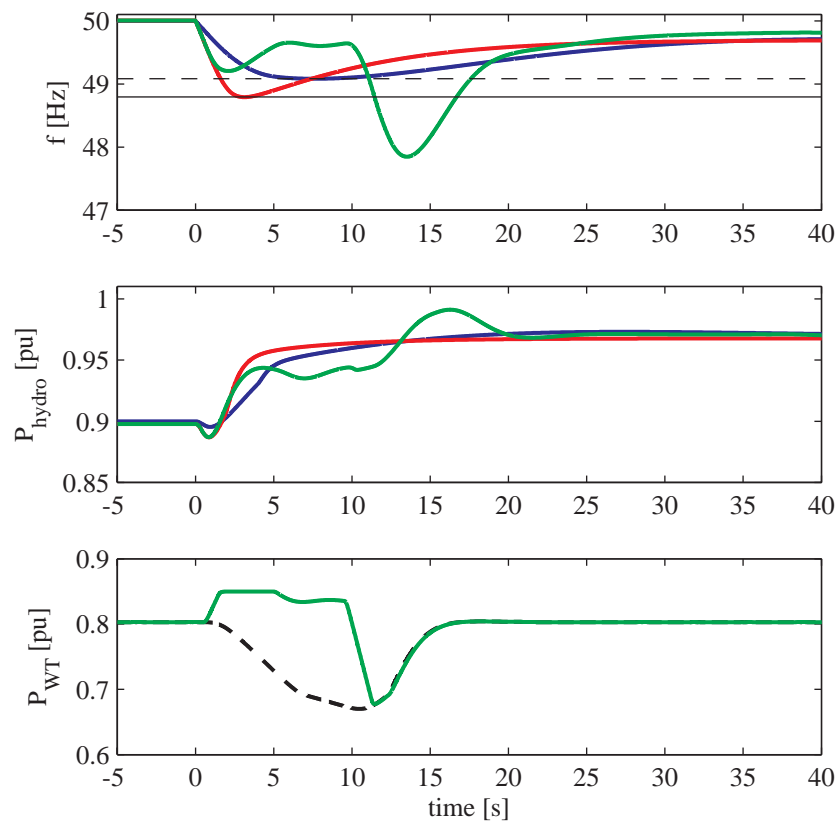

Figure 7.5 30 000 MW load, loss of 1 400 MW thermal production. Without wind power (blue), with 12 000 MW uncontrolled wind power (red) and with 12 000 MW Δf -controlled wind power (green). $f_{deadband}=49.9$ Hz, $f_{controlband}=49.5$ Hz, $P_{inc}=0.05$ pu, $t_{inc}=9$ s, $t_{dec}=1$ s. At the bottom dashed line is P_{order} and solid line is P_{ref} .

When the maximum time of overproduction, $t_{inc}=9$ s, is reached the additional power is ramped down and transition to a power reference determined by the optimal speed control is done during 1 s. The dashed line at the bottom is power ordered by the speed controller, i.e. P_{order} . With this high level of wind power the additional 0.05 pu power has large influence on system frequency. Initially the frequency dip is improved as compared to the case without any control and also compared to the initial case without wind power. But after the 9 s, the frequency is still outside the deadband and the following recovery in turbine speed causes a severe frequency dip. In this case the controller is actually devastating to the system frequency. When comparing to the df/dt -controller in Chapter 6 it is obvious that the increase in power is too long for the purpose of supporting the frequency similar to the natural inertial response. An important reason is that it causes an undesired low and slow initial increase from the hydro units.

Varying Controller Parameters

From the previous simulation it is clear that it would be preferable to start the decrease of the additional power earlier. Hence the controller parameters are varied in an attempt to make the controller suitable for the system with hydropower and high level of wind power.

In Figure 7.6 the length of the power increase is varied according to $t_{inc}=2, 5, 9$ s while the decrease time t_{dec} is kept constant at 1 s.

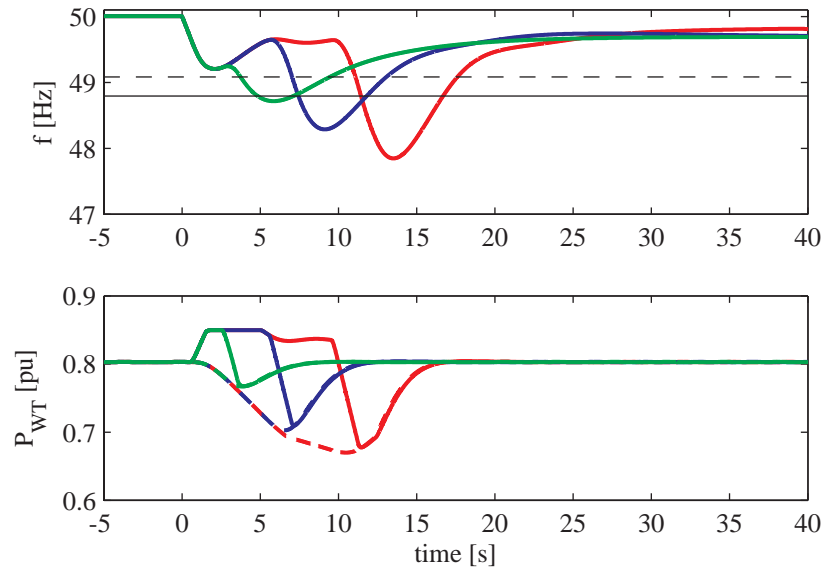

Figure 7.6 30 000 MW load, 12 000 MW wind power production, loss of 1 400 MW thermal production. Δf -controlled wind power with $t_{dec}=1$ s and $t_{inc}=2$ s (green), $t_{inc}=5$ s (blue) and $t_{inc}=9$ s (red). Black dashed line indicates lowest frequency without wind power and black solid line with uncontrolled wind power. At the bottom dashed lines are P_{order} and solid lines are P_{ref} .

Once again the simulations show that it is difficult to get any improvement with this controller. In all these three cases the frequency is lower than without control and the undesirable second dip is obvious.

In an attempt to improve the transition back to normal operation t_{dec} is extended in Figure 7.7. t_{inc} is held constant at 2 s while t_{dec} is increased to 10, 15 and 20 s respectively.

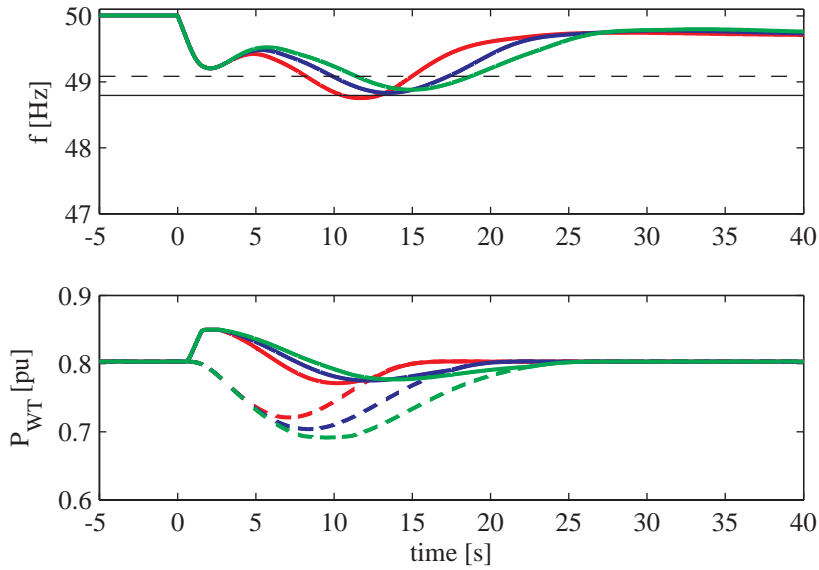

Figure 7.7 30 000 MW load, 12 000 MW wind power production, loss of 1 400 MW thermal production. Δf -controller with $t_{inc}=2$ s and $t_{dec}=10$ s (red), 15 s (blue) and 20 s (green). Black dashed line indicates lowest frequency without wind power and black solid line with uncontrolled wind power. At the bottom dashed lines are P_{order} and solid lines are P_{ref} .

A frequency nadir at about the same level as without control is now possible, which is of course still unacceptable. As it seems as the power increase is too high, lower power increase of 0.01 and 0.03 pu is tested in Figure 7.8. The results are a little better with $P_{inc}=0.03$ s but the second dip is still substantial.

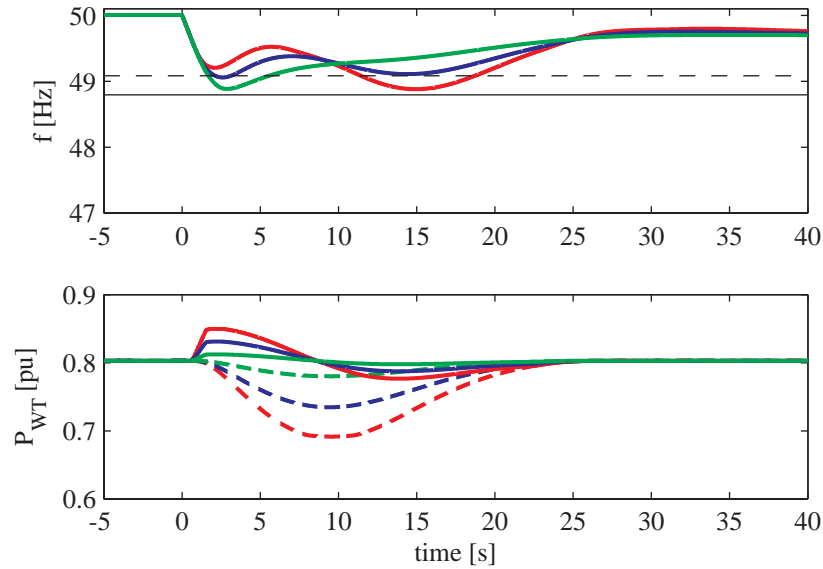
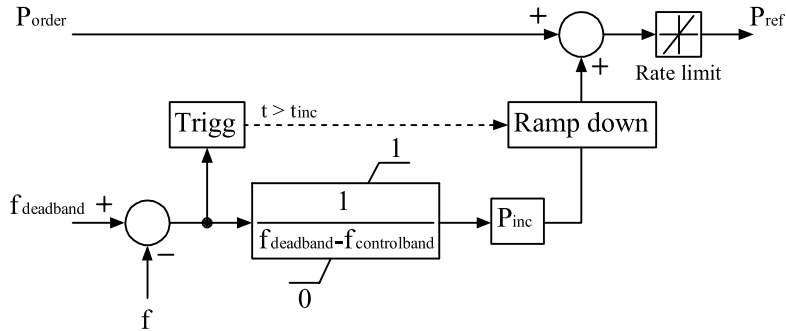

Figure 7.8 30 000 MW load, 12 000 MW wind power production, loss of 1 400 MW thermal production. Δf -controller with $\tau_{inc}=2$ s and $\tau_{dec}=20$ s. $P_{inc}=0.01$ (green), $P_{inc}=0.03$ (blue), $P_{inc}=0.05$ (red). Black dashed line indicates lowest frequency without wind power and black solid line with uncontrolled wind power. At the bottom dashed lines are P_{order} and solid lines are P_{ref} .

For this system and load situation it seems very difficult to find controller settings that give an acceptable performance. One conclusion this far is the importance of a fairly fast decrease of the additional power. At the same time the decrease has to be smooth enough to avoid the second dip. Since this seems impossible to achieve by adjusting the settings of the tested controller some changes in the controller structure is made in the next section.

7.3 Δf -controller with Smoother Recovery

Instead of adding P_{inc} to the predisturbance power reference, P_{inc} is now added to P_{order} , i.e. the power ordered by the optimal speed function, see Figure 7.9. This implies a smoother transition back to normal operation as shown to the left in Figure 7.2.

Figure 7.9 Δf -controller.

In Figure 7.10 controllers that do and do not take speed into account, are compared. Both with a setting of $t_{inc}=10$ s and $t_{dec}=20$ s.

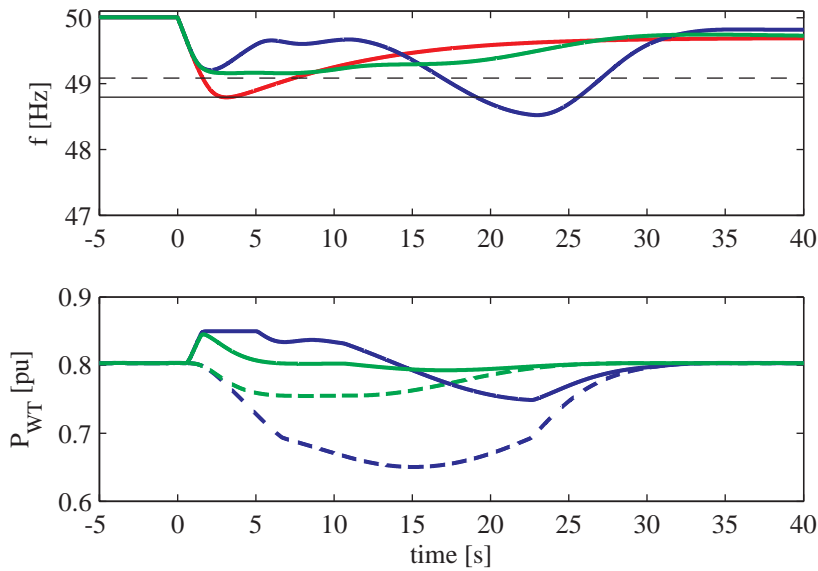

Figure 7.10 30 000 MW load, 12 000 MW wind power production, loss of 1 400 MW thermal production. Δf -controller with $t_{inc}=10$ s $t_{dec}=20$ s. $P_{ref}=P_{order}$ (red), $P_{ref}=\text{hold}(P_{order})+P_{inc}$ (blue) and $P_{ref}=P_{order}+P_{inc}$ (green). Black dashed line indicates lowest frequency without wind power and black solid line with uncontrolled wind power. At the bottom dashed lines are P_{order} and solid lines are P_{ref} .

When taking speed into account the transition back to normal operation is effectively improved and the second dip is eliminated. This controller gives a slightly higher and better minimum frequency than without any wind power, however the frequency recovery is slightly slower than for the case without control.

Tuning the Smooth Recovery Controller

Also with this smooth recovery controller the parameters are varied to find the best option for frequency support. In Figure 7.11 the time t_{inc} is varied between 2, 5 and 10 s while t_{dec} is kept constant at 20 s.

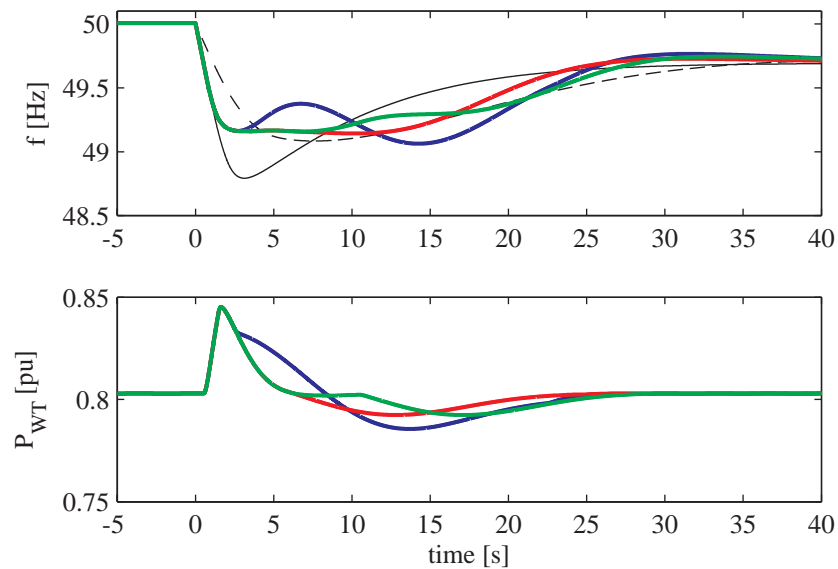

Figure 7.11 30 000 MW load, loss of 1 400 MW thermal production. Without wind power (black dashed), with 12 000 MW uncontrolled wind power (black solid), with 12 000 MW controlled wind power. Δf -controller: $t_{inc}=2$ (blue), 5 (red), 10 s (green), $t_{dec}=20$ s. $P_{ref}=P_{order}+P_{inc}$

The time before starting the transition back to normal operation is fairly critical. In this case $t_{inc}=5$ s seems as the best option without any second dip. The frequency deviation is slightly improved also compared to the initial case without any wind power.

Varying Wind Power Penetration

It is now shown that a Δf -controller with correct settings can improve the

frequency deviation but the question is whether or not the settings are suitable also for other scenarios. To further investigate this, the level of wind power is varied while the load is the same as before, i.e. 30 000 MW. The level of wind power is 10%, 20% and 30%, Figure 7.12. The wind power displaces thermal power which gives inertia values of 112 800, 88 800 and 64 800 MWs respectively.

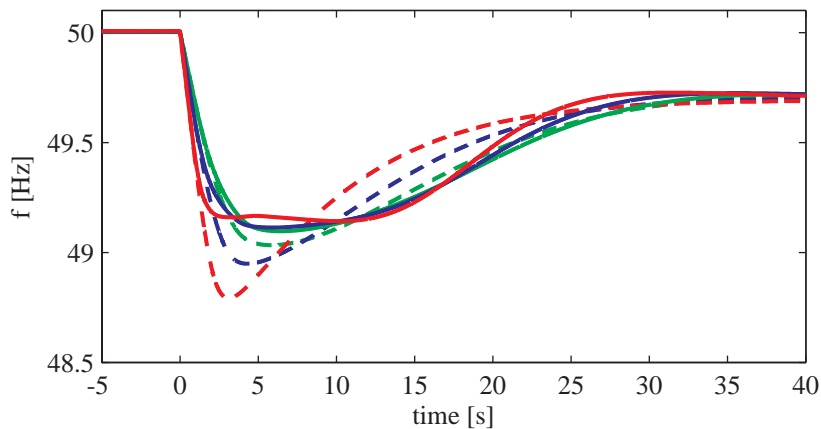

Figure 7.12 30 000 MW load, loss of 1 400 MW thermal production. Wind power without control (dashed). Wind power with Δf -controller (solid). $t_{inc}=5$ s, $t_{dec}=20$ s. 10% (green), 20% (blue) and 30% (red) wind power. $P_{ref}=P_{order}+P_{inc}$

These settings work well for the three simulated levels of wind power penetration and an improved frequency nadir is obtained in all cases.

7.4 Generally Defined Frequency Support Controller

As demonstrated above it is possible to improve the frequency nadir by means of a Δf -controller but the transition back to normal operation is very critical and is dependent on the wind turbine optimal speed controller. This is not preferable since the behaviour then varies between different operating points and between different turbines and manufacturers. Instead generally defined requirements for the behaviour during a low frequency event are preferable. Therefore an attempt is made to define a more general controller with a given power increase and given ramp rates. It is already clear that delivering high temporary power during a long period of time is not desirable. This will only result in a postponed and more severe frequency dip. Given this, an output power change according to Figure 7.13 is suggested. The curve is chosen to

be shaped similar to the natural inertial response but still easy to define.

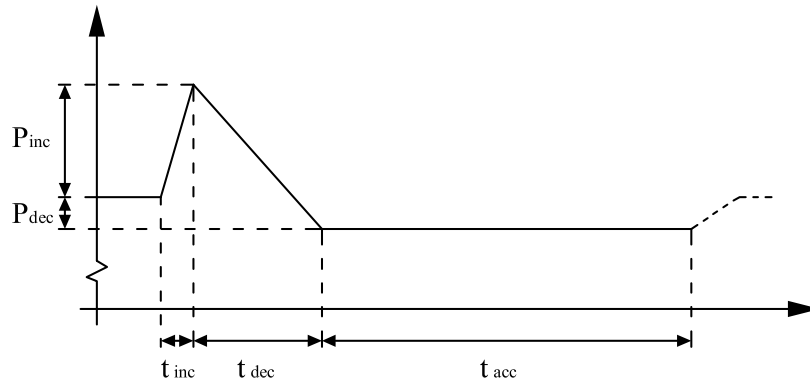

Figure 7.13 Proposed definition of power increase and duration for a frequency support controller.

The dashed line following the acceleration period is indicating that the transition back to normal operation can be decided by the manufacturers. However it is suggested that the acceleration power level is maintained until the power ordered by the optimal speed controller, P_{order} , is higher than the output power. From this point the output power is again determined by the speed controller and maximum power operation will be obtained. If t_{acc} is exceeded a smooth transition back to P_{order} is suggested. Since the reduction in natural inertia is related to production from wind power rather than rated power, the power increase is given in percent of predisturbance power instead of percent of rated power.

Fixed Power Increase

In Figure 7.14 the frequency support controller is simulated for the same case as previously. When the frequency falls below 49.9 Hz the controller is triggered and the power reference is increased by 6% with a ramp rate of 0.1 pu/s. After 0.5 s the additional power is ramped down during 4 s to a value 0.5% below the predisturbance value. The turbine is now accelerated. When the power ordered by the optimal speed controller (dashed line in Figure 7.14) is equal to the current output power (solid line) the output power is again determined by the speed controller and normal operation is restored.

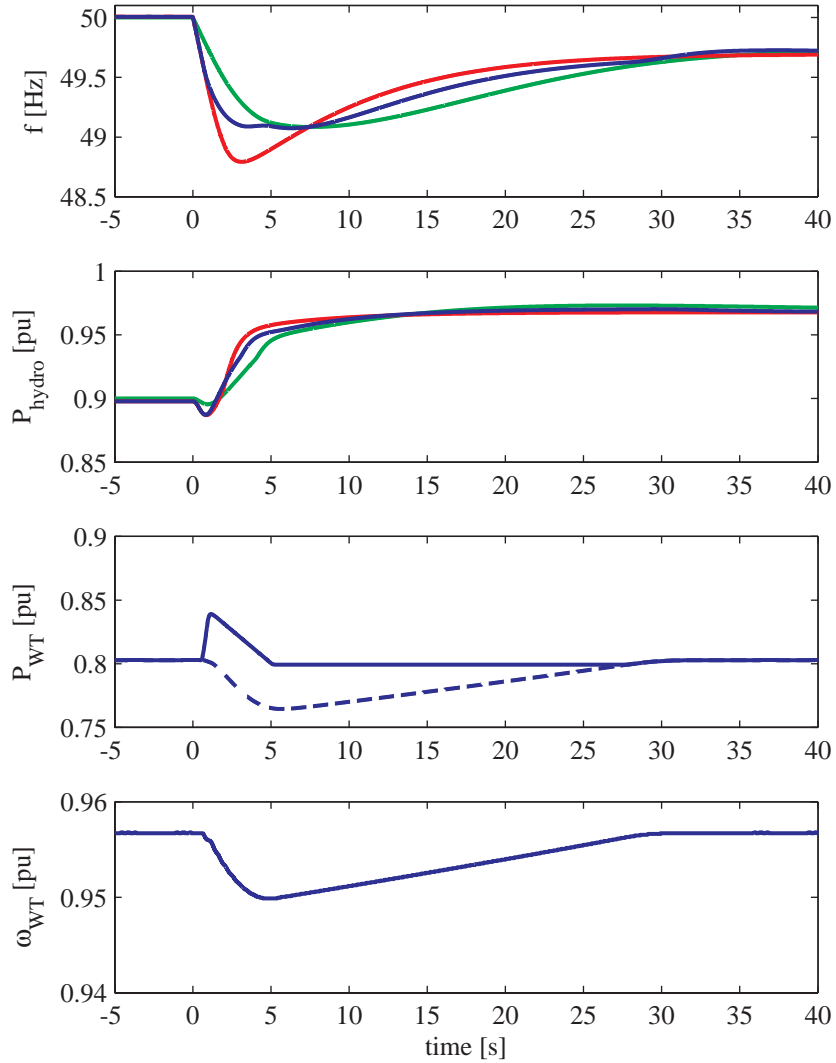

Figure 7.14 30 000 MW load, 12 000 MW wind power production, loss of 1 400 MW thermal production. Without wind power (green), wind power without control (red), wind power with frequency support (blue) $P_{inc}=6\%$.

The controller does not have any influence on the initial df/dt but more important is that the frequency nadir is improved and increased to the same value as without any wind power. The frequency variation is smooth and

without any second dip. Also the hydropower turbine governors performs well in combination with this frequency support controller.

The controller parameters have been adjusted to give the best performance for this specific case. However the controller has to be generally applicable to all possible operation situations and disturbances. To verify this some further cases are simulated. In Figure 7.15 the loss of generation is reduced from 1 400 MW to 700 MW.

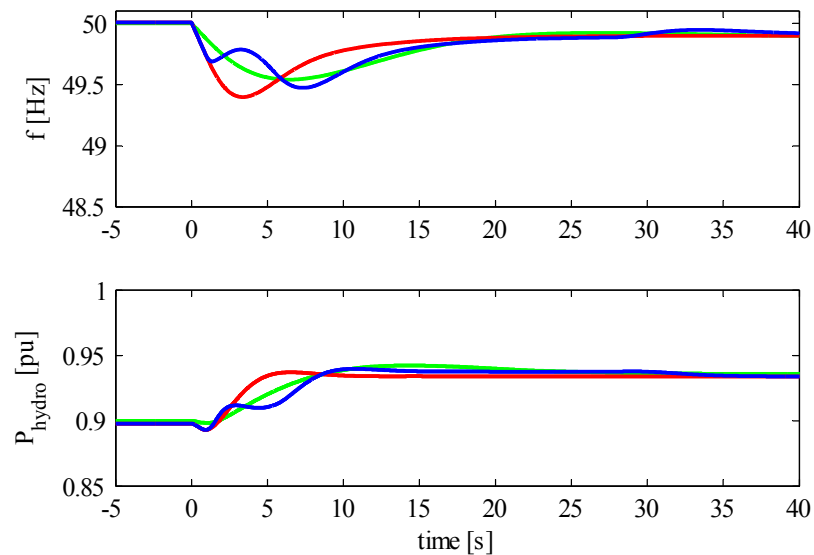

Figure 7.15 30 000 MW load, 12 000 MW wind power production, loss of 700 MW thermal production. Without wind power (green), wind power without control (red), wind power with frequency support (blue). $P_{\text{inc}}=6\%$.

It is obvious that a controller with fixed power increase does not suit all situations. With the 700 MW step the frequency is higher than without control indeed, but the hydropower is controlled upwards, then downwards and finally upwards again, which is not preferable. The main problem is that the power increase is too high to meet the lost generation.

Power Increase Proportional to Δf

To make the controller suitable for different disturbance magnitudes the initial power increase is now made proportional to frequency deviation. In the following simulations the additional power is linearly increased between 49.9 and 49.6 Hz. The maximum increase is 10% but this value will never be reached due to the 0.1 pu rate limit and the fact that the decrease starts 0.5 s after the increase function is triggered. The power is ramped down to a value 0.5% below initial power during 4 s. The three cases shown in Figure 7.16 are loss of 400 MW, 900 MW and 1 400 MW generation. For all these cases the controller gives a minimum frequency almost equal to the value without any wind power.

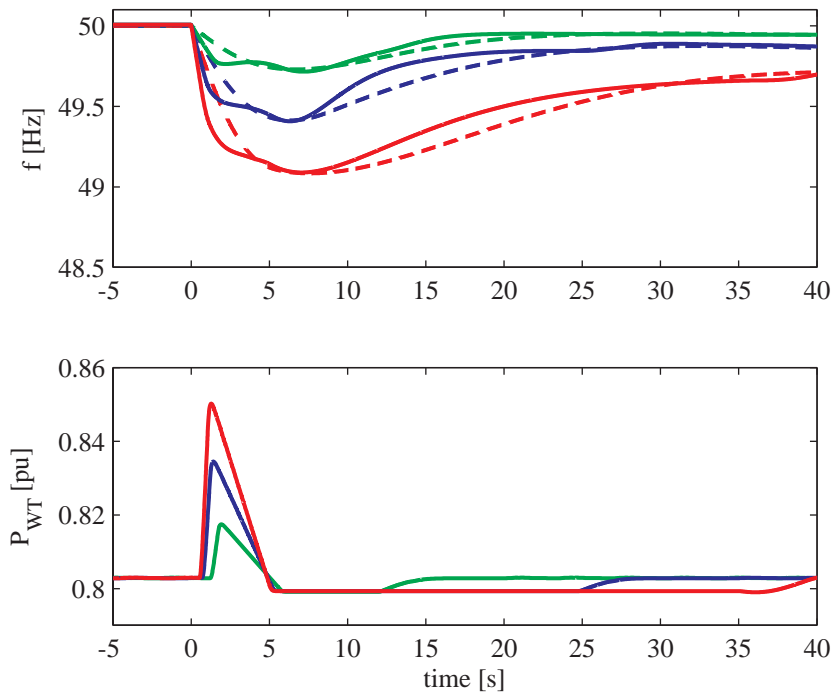

Figure 7.16 30 000 MW load, 12 000 MW wind power production. Loss of 400 MW (green), 900 MW (blue) and 1 400 MW (red) generation. Without wind power (dashed), with controlled wind power (solid). $P_{inc}=10\%$, proportional to Δf .

Sensitivity Analysis

The controller can now handle different disturbance magnitudes satisfactory. In the following simulations wind power penetration, system inertia and wind speed are varied to further verify the controller behaviour. The disturbance is loss of 1 400 MW thermal production in all cases.

Varying Wind Power

In Figure 7.17 the wind power penetration is varied between 5 000 MW, 10 000 MW and 15 000 MW. This gives a resulting system inertia of 112 800 MW, 88 800 MW and 64 800 MW respectively.

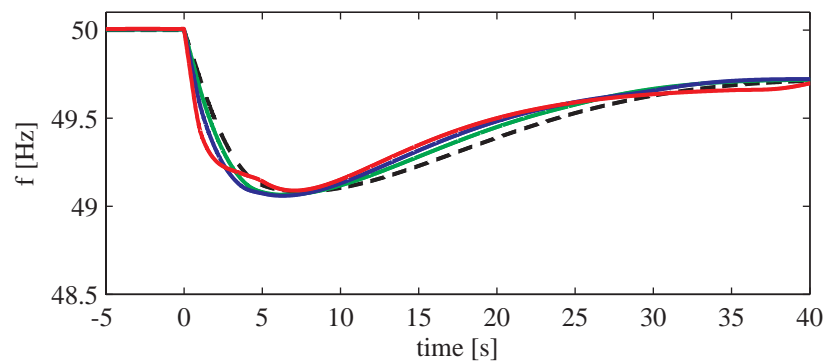

Figure 7.17 30 000 MW load. Loss of 1 400 MW generation. Without wind power (black), with 5 000 MW (green), 10 000 MW (blue) and 15 000 MW (red) installed wind power with frequency control. $P_{inc}=10\%$, proportional to Δf .

The controller shows acceptable performance for the three simulated cases, but it shall be noted that the controller tuning is critical and a too weak or too strong frequency response may be obtained.

Varying System Inertia

This far the system inertia has been quite low in the simulations. In Figure 7.18 a system with 50 000 MWs, 75 000 MWs and 100 000 MWs is tested with 15 000 MW uncontrolled and controlled wind power, producing 12 000 MW.

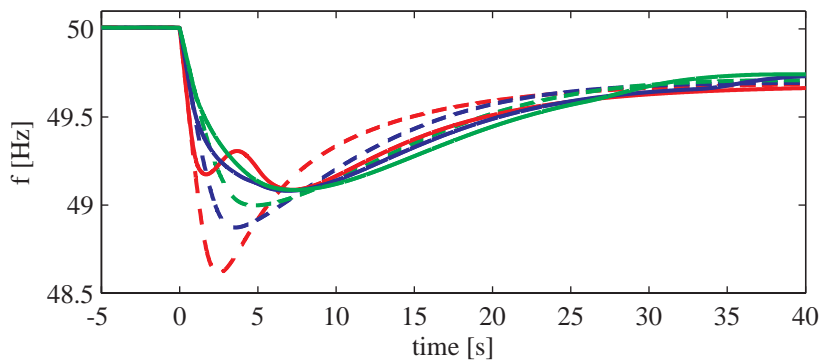

Figure 7.18 30 000 MW load. Loss of 1400 MW generation with uncontrolled (dashed) and controlled wind power (solid). $S_n H=50$ GWs (red), 75 GWs (blue) and 100 GWs (green). $P_{inc}=10\%$, proportional to Δf .

The controller improves the lowest frequency in all cases although the frequency has two dips in the case with lowest inertia. With 75 000 MWs the control is much better and the frequency improvement is significant. Frequency support from wind power is actually not necessary with 100 000 MWs since the frequency is above 49 Hz anyway, however the controller further improves the frequency nadir. The fact that the frequency is not perfect with the lowest inertia shall not be paid too much attention to since the inertia values are only roughly estimated and a small increase by 25 000 MWs makes a great improvement.

Varying Wind Speed

In Figure 7.19 the wind speed is varied. With decreasing wind speed the lost wind power production is replaced by traditional thermal production which increases the system inertia. It is then possible to reduce the wind power frequency response. This is achieved due to the fact that the additional power is proportional to the predisturbance power.

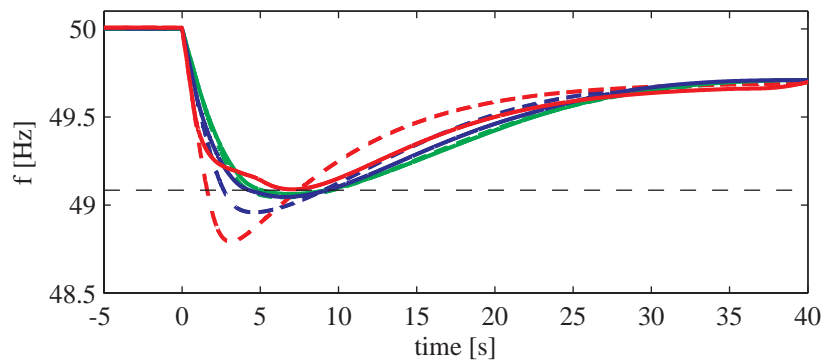

Figure 7.19 30 000 MW load. Loss of 1400 MW generation with uncontrolled (dashed) and controlled wind power (solid). 15 000 MW installed wind power producing 0.8 pu (red), 0.5 pu (blue) and 0.2 pu (green). $P_{inc}=10\%$, proportional to Δf . Black dashed line indicates lowest frequency without wind power.

For the different wind speeds the controller improves the frequency nadir to about the same level as without any wind power.

7.5 Curtailed Wind Power with Droop Control

Until now it has been assumed that the wind power is operated to extract maximum available power from the wind. Now the wind turbines are assumed to be operated 4% below the available aerodynamic power instead. The remaining 4% is used as a traditional frequency control with droop, i.e. the power increases linearly with frequency deviation, in this case between 49.9 and 49.5 Hz. With the assumption of a reduction in percentage of available power the frequency response will vary with wind speed. With lower wind speed the frequency response is decreased but at the same time, with decreased wind speed the traditional synchronous generation is increased and hence reduces the need of wind power frequency control due to higher inertia.

Sensitivity Analysis

The performance of wind power operated in traditional droop-based frequency control mode is investigated in the following simulations where the disturbance magnitude and the wind speed are varied.

Varying Disturbance

In Figure 7.20 the loss of thermal production is 400 MW, 900 MW and 1 400 MW. The wind power is operated 4% below maximum available power. Available power equals 0.8 pu.

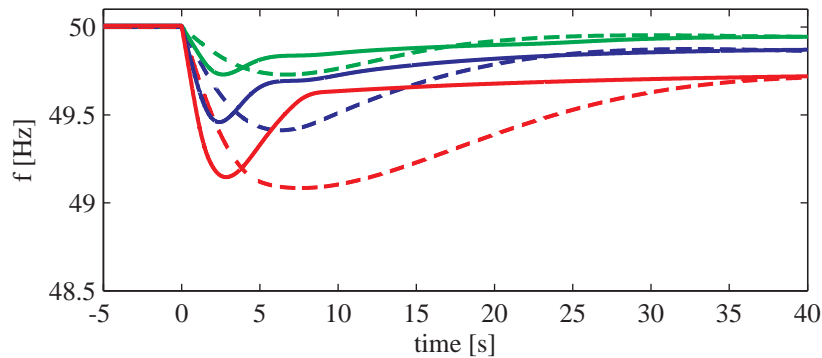

Figure 7.20 30 000 MW load. Curtailed wind power with droop control. $P_{inc}=4\%$ pu linearly increased between 49.9 and 49.5 Hz. Loss of 400 MW (green), 900 MW (blue) and 1 400 MW (red) generation. Without wind power (dashed), with controlled wind power (solid).

A minimum frequency at about the same level as without wind power is obtained. The initial frequency recovery is very fast and no problem with a second dip will occur due to the 4% of extra available aerodynamic power. When the frequency has stabilized it is possible to decrease the wind turbine set point again to be prepared for a new disturbance. However this is expected to be done in the same time scale as the secondary frequency control, i.e. later than the 40 s shown in Figure 7.20.

With wind power operating with curtailed output power it is possible to regard the additional power as a traditional frequency control. In the case, with a wind power production of 12 000 MW, the additional frequency response is

$$\frac{4\% \cdot 12\,000 \text{ MW}}{49.9 - 49.5 \text{ Hz}} = 1\,200 \text{ MW/Hz} \quad (7.1)$$

This may be compared to the normal operating reserve of 6 000 MW/Hz and the disturbance reserve of 3 000 MW/Hz.

Varying Wind Speed

Figure 7.21 shows the wind power frequency droop control at different wind speeds.

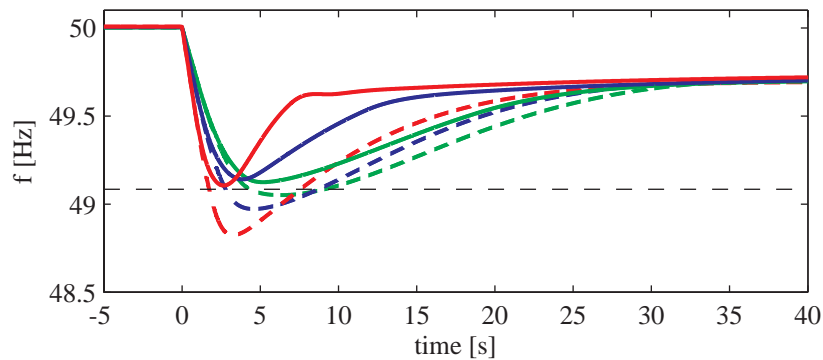

Figure 7.21 30 000 MW load. Loss of 1400 MW generation. Curtailed wind power with droop control. $P_{inc} = 4\%$ linearly increased between 49.9 and 49.5 Hz. Uncontrolled (dashed) and controlled wind power (solid). 15 000 MW installed wind power producing 0.8 pu (red), 0.5 pu (blue) and 0.2 pu (green). Black dashed line indicates lowest frequency without wind power.

For the tested wind speeds, giving a production of 0.2 – 0.8 pu, the controller maintains a frequency at about the same level as without any wind power in the system.

7.6 Summary

Typically wind turbine manufacturers show frequency response from their

turbines for a frequency that can not be affected by the turbine itself. In a system with high level of wind power this approach is insufficient as the wind power can affect the system frequency and a feedback in measured frequency is achieved. Hence the entire system has to be considered.

If controlling the active power to increase for example 0.1 pu for about 10 s, like some references suggest, problems with the traditional frequency control may occur. The frequency may actually be further aggravated compared to the case without any wind turbine frequency control. The most aggressive wind turbine frequency controller response is not always the best from the power system point of view. Since the wind turbine speed needs to be recovered, an initially strong control effort will only postpone the problem provided that the turbine is not operated in curtailed mode. The problems related to the Δf -controller are worst with low system inertia, which are the cases where it is needed most.

It is shown that a frequency support controller with fixed ramping times and a power increase proportional to frequency deviation can be tuned to acceptable performance. However the tuning is critical and a too weak or too strong frequency response may be obtained. Hence the controller shall be used with great caution in a real system where many parameters are unknown or uncertain.

If the wind turbines are operated in curtailed mode the risk of a second frequency dip is eliminated. It is then possible to consider the wind power frequency control as equal to the traditional turbine governors and thus have a predictable reserve and frequency response.

It shall be noted that some of the controllers that have been found inappropriate here might be suitable for systems with higher inertia as compared to wind power penetration. However as the problems related to frequency dynamics are worst in the cases with extremely low inertia, those cases have been considered most relevant to investigate. With slightly increased inertia the Nordic system is most likely to handle a disturbance anyway, see Chapter 4. Further, other systems with for example less hydropower may give somewhat different results.

The frequency support controller has no positive effect on the initial df/dt . However the maximum df/dt is well below 2 Hz/s limit in all the simulated cases.

Chapter 8

Discussion

In the two previous chapter two different strategies to improve frequency dynamics, i.e. df/dt -controller and Δf -controller, were investigated. In this chapter the different control strategies are discussed and compared. Some recommendations are given and opinions from TSOs regarding synthetic inertia are reviewed.

8.1 Performance of Investigated Controller Types

There seems to be no single optimal solution for obtaining frequency response from non-synchronously connected generation. Each of the investigated control options has their advantages and disadvantages.

A df/dt -controller acting on directly measured frequency, or a frequency with a light filtering with a 1 Hz low-pass filter, give a frequency response similar to that of a synchronous generator. Moreover, it can improve the damping of power oscillations in the system. The drawback is that the mechanical parts of the wind turbine are subjected to some periods of the oscillations. This controller is best suited for a situation with high level of wind power as the wind power is strong enough to affect the system frequency and damp the oscillations. In order to minimize the mechanical wear of the turbine the additional power ordered by the controller is rated limited to 0.1 pu/s in all the simulations.

If the filter bandwidth is reduced to about 0.05 Hz the controller does not act on the oscillations in measured frequency and a smooth output power is obtained. Another advantage with the heavier filtering is that a delayed wind turbine response improves the overall frequency dynamics and the frequency nadir is improved. This is due to a faster and higher response from hydro units. On the other hand, this controller does not improve the damping of the power oscillations in the system.

When using the average frequency estimation algorithm in the df/dt -controller the oscillations in wind turbine output power is of smaller amplitude as compared to the case with a 1 Hz filter but the behaviour is not improved compared to the case with 0.05 Hz filter. Nor does it add damping of the oscillations in the system.

With the Δf -controller a too strong frequency response can be obtained if the controller is not handled with great caution. Delivering high additional power may be devastating to the overall frequency dynamics if the level of wind power is high. The advantage of this controller is that the output power is smooth as it does not act on possible oscillations in the system to the same extent as the df/dt -controller. The immunity to noise in the measured frequency is also better than for the df/dt -controller.

Another option with the Δf -controller is to use it in combination with curtailed wind turbine output power. The frequency response and available reserve is then predictable in the same way as with traditional frequency control and the risk of having a too high or too low wind turbine response is eliminated. An operating point 4% below available aerodynamic power is sufficient according to the simulations. The investigated controllers are

Table 8.1 Synthetic inertia and frequency support controller performance.

Controller type	Test systems	Low wind case	High wind case
df/dt -controller 1 Hz filter on f	4 machine system Nordic1/1	Large osc. in WT output power	Few periods of osc. in WT output power Power system osc. well damped
df/dt -controller 0.05 Hz filter on f	4 machine system Nordic1/1	Small osc. in WT output power Best frequency nadir	Small osc. in WT output power Best frequency nadir
df/dt -controller estimated f	4 machine system	Moderate osc. in WT output power	Moderate osc. in WT output power
Δf -controller max P	Nordic1/1	Acceptable performance	Acceptable performance but difficult to tune
Δf -controller curtailed P	Nordic1/1	Good performance with deterministic frequency response	Good performance with deterministic frequency response

summarized in Table 8.1. Despite increased rate of change of frequency, the margin to the 2 Hz/s limit in ENTSO-E Draft Requirements for Grid Connection (ENTSO-E 2011) is good for all the investigated controllers.

8.2 TSO Requirements on Synthetic Inertia

During the last years some TSOs have shown interest in synthetic inertia. Hydro Québec was early to require that a wind power plant must have an inertia emulation system that acts on major frequency deviations with a performance “at least as much as does the inertial response of a conventional synchronous generator whose inertia (H) equals 3.5 s”. In (Brisebois et al. 2011) a deeper investigation by Hydro Québec, is presented. A somewhat different definition of the requirements is then developed in cooperation with ENERCON and REpower. A controller defined with power increase, power decrease and time for these actions is found to be a better option than requiring an equivalent inertia. The controller is tested for a system with 2 000 MW wind power and 13 500 MW load. As has been shown in Chapter 7 the tuning of such a controller is very sensitive and the results are highly dependent on the wind power penetration and system parameters. It is also uncertain how the controller will react on a small disturbance that pushes frequency just outside the deadband. In such case the loss of production is fairly small but the power increase from the wind power is equal to the one at a larger production loss. This may result in an excessive power increase, too fast frequency recovery and possible overfrequency.

In Europe there are different opinions on appropriate requirements:

National Grid has studied frequency response and synthetic inertia during the last years. In the Frequency Response Technical Sub-Group Report (National Grid 2011) it is recommended to require fast frequency response instead of synthetic inertia. The active power reserve shall be fully available in 5 s and sustained for at least a further 25 s.

In ENTSO-E Draft Requirements for Grid Connection (ENTSO-E 2011) it is stated that a type C unit (a synchronous generating unit or power park module connected below 110 kV and with a maximum capacity above 10 MW) without natural inertia may be required to provide synthetic inertia. The grid operator in cooperation with the TSO “shall have the right to require a power generating facility to deliver an equivalent performance by an increase of active power related to the rate of change of frequency”.

The RenewableUK Position Paper on Inertia (RenewableUK 2011)

recommends not using synthetic inertia. Instead the TSO may contract a faster frequency response or they have an option of contracting natural inertia. This will be controlled by a trade off between inertia and frequency response costs.

It is clear that there are various opinions regarding synthetic inertia, how to define it and what to require. The uncertainty leads to dissatisfaction among the wind turbine manufacturers (Christensen et al. 2011). A problem is that general requirements are not easily defined as the entire system has to be taken into account. Different systems with different types of production and wind power penetration have different needs. The recommendations given in the next section are valid for the simulated Nordic system.

8.3 Recommendations

Problems related to frequency dynamics will probably not appear in the near future since such problems are slowly growing as the system inertia is reduced due to increased non-synchronously connected generation. Nevertheless, since changing requirements is a long process, these problems have to be addressed before they arise.

The most obvious solution for maintaining acceptable frequency dynamics is to ensure that a minimum level of natural inertia is maintained. Another simple solution is to increase the reserve and frequency response from traditional generation such as hydropower units.

If synthetic inertia, or frequency support, from wind power becomes necessary, the Δf -controller in combination with curtailed wind power is the absolutely safest way to improve the frequency dynamics. The second best option is the df/dt controller with 0.05 Hz filter. These two controllers give the most predictable frequency response and do not act on low frequency power system oscillations.

If some periods of low frequency oscillations in wind turbine output power is regarded acceptable the df/dt -controller with 1 Hz low-pass filter is also a valid candidate, especially since it has the positive effect of increasing system damping in a high wind situation. This is also the controller giving a frequency response closest to the one of a synchronous generator.

The option of operating traditional synchronous generation with reduced power to maintain the natural inertia in low load situations shall also be considered. Actions for improving the frequency dynamics are necessary only

in situations with very low load and high wind power production. As these occurrences are expected to be few, the option with increasing natural inertia, increasing governor response or curtailed wind power may be reasonable although they give lower efficiency. Which of the three last options to choose has to be determined by the cost related to each of them.

8.4 Verification of Synthetic Inertia Response

Linked to requirements is the question of how to assess compliance with the requirements. This applies also to requirements on synthetic inertia. Wind turbine manufacturers often show the performance of their turbines with a step increase in power reference (Wachtel et al. 2009), (Dernbach et al. 2010). (Knüppel et al. 2011) show wind turbine output power as the frequency is linearly decreased down to a constant level. None of these approaches gives any information about the wind turbine behaviour in a low inertia system with high wind power penetration. To be able to verify the wind turbine performance it is essential to use a system with feedback. To achieve this there are mainly two available options, except running simulations. The first, and most simple, is to await a frequency disturbance and then record the turbine output power. Such measurements are of course very important but it is not optimal to simply wait for a disturbance, hoping everything will work as expected. A test method giving an indication that the controller acts as expected is needed. One possibility is to take the frequency feedback signal to the wind turbine from an emulated power system, implemented in a computer. Then the turbine output power is measured and sent to the emulated system. The inertia, governor response and disturbance can then be arbitrarily selected to a certain scenario. This is the same approach as used when evaluating frequency response from hydropower stations (Granfors 2010).

8.5 Validity of Results

In this thesis only underfrequency is discussed. Of course overfrequency will occur if a large load area is disconnected or exporting interconnections are lost. However no reserves are necessary to handle such an event and the control is therefore simpler. Wind turbine manufacturers offer the possibility to reduce output power during a high frequency event, which is done in the same way as with the traditional frequency control.

Most of the simulations are made with a simple power system model omitting voltage variations. Introducing voltage variations and voltage dependent load is likely to improve the frequency dynamics. The simplifications thus provide

conservative results.

Although most of the simulation results are obtained with a simple FSC wind turbine model the results are applicable to DFIG based machines as well. Since the converter power control is assumed to be fast the type of variable speed turbine used does not affect the general conclusions.

The results in this thesis are general for the Nordic system and the assumption of maximum installed wind power does not affect the conclusions.

8.6 Summary

The advantages and disadvantages of some different controller types have been discussed. Depending on the system and on what to prioritize, a stable system or minimum mechanical stress on the wind turbines different controllers are preferable. From the power system point of view the df/dt -controller with a 1 Hz filter is preferable due to the increased system damping. For the wind turbines on the other hand, the Δf -controller in combination with curtailment or the df/dt -controller with 0.05 Hz filter are preferable. Present and coming synthetic inertia requirements from TSOs were also summarized. A large discrepancy between the different opinions was found which reflects the complexity of the question. The complete conclusions of the thesis are given in the next chapter.

Chapter 9

Conclusions

As non-synchronously connected generation is introduced in the power system the level of conventional synchronous generation is decreased and consequently the system inertia decreases. This will lead to higher rate of change of frequency (df/dt) and larger frequency variations. The frequency dynamics can be improved by increasing inertia, increasing governor response or with synthetic inertia or frequency support from wind turbines. In this thesis these options have been investigated for the Nordic power system and the results are summarized in this chapter which ends with some ideas for future work.

9.1 Summary of Results

Mainly two options for improving frequency dynamics by means of active control actions in wind turbines are available, the df/dt -controller and Δf -controller. A df/dt -controller temporarily increases output power in relation to the rate of change of frequency. If measured frequency is slightly filtered with a 1 Hz low-pass filter this controller gives a wind turbine frequency response similar to that of a conventional synchronous generator. Further this controller improves the damping of electromechanical oscillations between (groups of) generators which has been shown in this thesis. However, the wind turbine has to withstand some periods of oscillation. This controller is best suited in a high wind situation where the wind power has great influence on system frequency.

In order to avoid a controller acting on the oscillations in measured frequency it is possible to use heavier filtering, e.g. a low-pass filter with 0.05 Hz cut-off frequency. Increased filtering delays the wind turbine response. This gives an increased response from hydro units which actually improves the overall frequency dynamics. Hence a too fast synthetic inertia control is not preferable.

The Δf -controller is best used in combination with curtailed wind turbine output power. A power reduction of 4% of available aerodynamic power is sufficient for a frequency support controller in the simulated Nordic system. It is possible to use the Δf -controller also when extracting maximum power from the wind. However defining the power-time profile for such a controller is very critical. If the controller is not handled with great caution and a too high response is obtained, the frequency problem will be postponed and even worse than without any control. Once again it has been shown that the fastest and most aggressive controller is not necessarily the best from the system point of view. The entire system has to be considered in order to verify wind turbine behavior in combination with already existing turbine governors.

With all the investigated controllers there is considerable margin to the 2 Hz/s limit, given in ENTSO-E Draft Requirements for Grid Connection, wherefore frequency deviation seems of most interest to improve.

If synthetic inertia, or frequency support, from wind power becomes necessary in the future, the Δf -controller in combination with curtailed wind power is the absolutely safest way to improve the frequency dynamics. The second best option is the df/dt -controller with 0.05 Hz filter. These are the two controllers giving the most predictable frequency response and minimum mechanical wear of the wind turbines.

In a power system such as the Nordic, frequency support from wind power will only be necessary in situations with low load and high wind power production. As such cases are expected to be few in a year, solutions such as deliberately increasing the natural inertia, increasing governor response or operating wind power in curtailed mode are considered feasible.

In simulations and laboratory tests it has been shown that the synchronous and induction generator capability of delivering power to the grid during a frequency disturbance is almost solely determined by the generator and turbine mechanical system, i.e. the amount of inertia. The induction generator has almost exactly the same behaviour as the synchronous generator during a frequency disturbance given equal mechanical systems.

As a thesis in the area of frequency dynamics and non-synchronous generation easily focuses exclusively on wind power, it is important to keep in mind that many of the results are generally applicable and actually more related to the power system than to wind power.

9.2 Future Work

The main focus of this thesis is on the Nordic power system and the conclusions are primarily valid under these conditions. A similar analysis for systems with other combination of production units would be interesting as the type of production may change the evaluation of the different control options.

A dimensioning fault occurring at 49.9 Hz instead of 50.0 Hz was not used when analyzing new wind turbine controllers since it seems difficult to handle already today. The simulations show that changing the requirements on minimum disturbance reserve and frequency control response may alleviate the problem. It is left for future work to investigate if this is the best solution or if it is better to change control strategy in hydropower units or if it might be solved by wind power control.

Damping in power systems with high level of wind power is of great concern and a deeper investigation of the possibility to improve damping with the df/dt -controller would be interesting to perform.

To investigate wind power frequency response as seen from the power system it was assumed that wind turbines could be aggregated. An investigation of the behavior inside a wind farm with the proposed controllers is left for future research.

In this thesis frequency dynamics during a major disturbance is studied. The effect of wind variations on frequency quality and the need of frequency control to meet wind variations are also important issues to investigate.

References

- Aeolus. SimWindFarm. <http://www.ict-aeolus.eu/SimWindFarm/index.html>.
- Akbari, M., Madani, S. M. (2010). "A New Method for Contribution of DFIG-based Wind Farms in Power System Frequency Regulation", *North American Power Symposium 2010*.
- Alm, E. (1956). *Elektroteknisk handbok*. Stockholm, Sweden: Bokförlaget Natur och Kultur (in Swedish).
- Assdourian, S. (2005). *Modell och analysverktyg för beräkning av frekvensförlopp*, Master thesis at KTH Royal Institute of Technology, Sweden (in Swedish).
- Bakken, B.H. (1997). *Technincal and economic aspects of operation of thermal and hydro power system*, Doctoral Dissertation at the Norwegian University of Science and Technology, Norway.
- Brisebois, J., Aubut, N. (2011). "Wind Farm Inertia Emulation to Fulfill Hydro-Québec's Specific Need", *2011 IEEE Power and Energy Society General Meeting*, San Diego, USA.
- Christensen, P. W., Tarnowski, G. C. (2011). "Inertia for Wind Power Plants – state of the art review – year 2011", *10th International Workshop on Large-Scale Integration of Wind Power into Power Systems as well as on Transmission Networks for Offshore Wind Farms*, Aarhus, Denmark.
- CIGRÉ (1995). CIGRÉ TF 38-02-08, *Long Term Dynamics Phase II*, Final Report, March 1995.
- Conroy, J. F., Watson, R. (2008). "Frequency Response Capability of Full Converter Wind Turbine Generators in Comparison to Conventional Generation", *IEEE Transactions on Power System*, vol. 23, no. 2, pp. 649-656.

- Dernbach, M., Bagusche, S., Schrader, S. (2010). "Frequency Control in Québec with DFIG Wind Turbines", *9th International Workshop on Large-Scale Integration of Wind Power into Power Systems as well as on Transmission Networks for Offshore Wind Farms*, Québec, Canada.
- DigSilent (2010). PowerFactory Manual, version 14.0.519.1.
- Divya, K. C., Hansen, A. D., Sørensen, P.E., Østergaard, J. (2008). "Variable Speed (DFIG) Wind Turbines: Rapid Frequency Response to Power System Disturbances", *European Wind Energy Conference*, Brussels, Belgium.
- EA Energy Analysis (2007). *50% Wind Power in Denmark in 2025*, Denmark.
- Ekanayake, J., Jenkins, N. (2004). "Comparison of Doubly Fed and Fixed-Speed Induction Generator Wind Turbines to Change in Network Frequency", *IEEE Transactions on Energy Conversion*, vol. 19, no. 4, pp. 800-802.
- ENTSO-E (2011). *ENTSO-E Draft Requirements for Grid Connection Applicable to all Generators*, 22 March 2011.
- EWEA (2012). *Wind in power, 2011 European statistics*.
- Facteau, M., Langlois, C. E., Marques, J., Jaskulski, I., Mendonça, Â. (2010). "Assessment of ENERCON WEC Grid Performance based on Hydro-Québec System Requirements: a cooperation between ENERCON and Hydro-Québec", *9th International Workshop on Large-Scale Integration of Wind Power into Power Systems as well as on Transmission Networks for Offshore Wind Farms*, Québec, Canada.
- Girgis, A. A., Peterson, W. L. (1990). "Adaptive Estimation of Power System Frequency Deviation and its Rate of Change for Calculating Sudden Power System Overloads", *IEEE Transactions on Power Delivery*, vol. 5, no. 2, pp. 585-594.
- Granfors, S. (2010). "Online testing of generating units on their ability to regulate frequency during restoration of an islanded grid", *2010 IEEE Power and Energy Society General Meeting*, Minneapolis, USA.

- Grunnet, J.D., Soltani, M., Knudsen, T., Kragelund, M., Bak, T. (2010). "Aeolus Toolbox for Dynamic Wind Farm Model, Simulation and Control", *The European Wind Energy Conference & Exhibition, EWEC*, Warszawa, Poland.
- Hagstrøm, E., Norheim, I., Uhlen, K. (2005). "Large-scale Wind Power Integration in Norway and Impact in Damping in the Nordic Grid", *Wind Energy*, vol. 8, pp. 375-384.
- Hansen, A. D, Sørensen, P. E., Iov, F., Blaabjerg, F. (2006). "Grid Support of a Wind Farm with Active Stall Wind Turbines and AC Grid Connection", *Wind Energy*, vol. 9, pp. 341-359.
- IEEE Working Group Report (1992). "Hydraulic Turbine and Turbine Control Models for System Dynamics Studies", *IEEE Transactions on Power System*, vol. 7, no. 1, pp. 167-179.
- Jauch, C., Sørensen, P., Norheim, I., Rasmussen, C. (2007). "Simulation of the impact of wind power on the transient fault behavior of the Nordic power system", *Electric Power System Research*, vol. 77, issue 2, pp. 135-144.
- Knüppel, T., Thuring, P., Kragelund, S., Nielsen, R., André, K. (2011). "Frequency Activated Fast Power Reserve for Wind Power Plant Delivered from Stored Kinetic Energy in the Wind Turbine Inertia", *10th International Workshop on Large-Scale Integration of Wind Power into Power Systems as well as on Transmission Networks for Offshore Wind Farms*, Aarhus, Denmark.
- Kundur P. (1994). *Power System Stability and Control*. New York: McGraw-Hill.
- Lalor, G., Mullane, A., O'Malley, M. (2005). "Frequency Control and Wind Turbine Technologies", *IEEE Transactions on Power System*, vol. 20, no. 4, pp. 1905-1913.
- Loukarakis, E. (2011). "Probabilistic Assessment of Wind Generation Effects on Primary Frequency Response", *IEEE PowerTech*, Trondheim, Norway.
- Marques, J. (2011). "Wind Energy Converter Models Validation", *1st Wind Integration Symposium*, Frankfurt, Germany.
- Matlab (2009). Simulink 7.4, R2009b, User's Guide.

- Miller, N. W., Clark, K., Shao, M. (2011). "Frequency Responsive Wind Plant Controls: Impacts on Grid Performance", *IEEE Power and Energy Society General Meeting*.
- Morren, J., de Haan, S. W. H., Kling, W. L., Ferreira, J.A. (2006). "Wind Turbines Emulating Inertia and Supporting Primary Frequency Control", *IEEE Transactions on Power System*, vol. 21, no. 1, pp. 433-434.
- Morren, J., Pierik, J., de Haan, S. W. H. (2006). "Inertial response of variable speed wind turbines" *Electric Power Systems Research*, vol. 76, issue 11, pp. 980-987
- National Grid (2011). "Frequency Response Technical Sub-Group Report", Tech. Rep., published 15 November.
- Nordel (1997). *Frekvens, tidsavvik, regulersyrke og reserve*, (in Norwegian).
- Nordel (2007). *Nordic Grid Code* (System Operation Agreement).
- Ramtharan, G., Ekanayake, J.B., Jenkins, N. (2007). "Frequency support from doubly fed induction generator wind turbine", *IET Renewable Power Generation*, vol.1, no. 4, pp. 3-9.
- RenewableUK (2011). "RenewableUK Position Paper on Inertia (V3-0)", Tech. Rep., published 7 April.
- Svensk Energi (2010). *Kraftläget i Norden och Sverige*, Sweden (in Swedish)
- Svensk Energi (2011). *The Electricity Year 2010*, Sweden.
- Tarnowski, G. C., Kjær, P. C., Sørensen, P. E., Østergaard, J. (2009). "Variable Speed Wind Turbines Capability for Temporary Over-Production", *Power and Energy Society General Meeting*.
- Tarnowski, G. C., Kjær, P. C., Dalsgaard, S., Nyborg, A. (2010). "Regulation and Frequency Response Service Capability of Modern Wind Power Plants", *Power and Energy Society General Meeting*.
- Ullah, N. R., Thiringer, T., Karlsson, D. (2008). "Temporary Primary Frequency Control Support by Variable Speed Wind Turbines – Potential and Application", *IEEE Transactions on Power System*, vol. 23, no. 2, pp. 601-612.

-
- Ullah N. R. (2008). Grid Reinforcing Wind Generation, Doctoral Dissertation at the Chalmers University of Technology, Sweden.
- Wachtel, S., Beekmann, A. (2009). "Contribution of Wind Energy Converters with Inertia Emulation to Frequency Control and Frequency Stability in Power Systems", 8th International Workshop on Large-Scale Integration of Wind Power into Power Systems as well as on Transmission Networks for Offshore Wind Farms, Bremen, Germany.

Appendix

The power transfer from one node to another in a power system is mainly dependent on the line reactance and the difference in phase angle between the nodes. The power transfer F between the nodes can be expressed as function of the net generation P in each node.

$$\begin{bmatrix} F_{12} \\ F_{13} \\ F_{23} \end{bmatrix} = \begin{bmatrix} M_{11} & M_{12} & M_{13} \\ M_{21} & M_{22} & M_{23} \\ M_{31} & M_{32} & M_{33} \end{bmatrix} \begin{bmatrix} P_1 \\ P_2 \\ P_3 \end{bmatrix} \quad (\text{A.1})$$

The net generation in each node can be expressed as the sum of power flowing into and out from the node

$$\begin{bmatrix} P_1 \\ P_2 \\ P_3 \end{bmatrix} = \begin{bmatrix} 1 & 1 & 0 \\ -1 & 0 & 1 \\ 0 & -1 & -1 \end{bmatrix} \begin{bmatrix} F_{12} \\ F_{13} \\ F_{23} \end{bmatrix} \quad (\text{A.2})$$

The flow from node m to n is determined by the phase angle between m and n and the admittance Y_{mn}

$$F_{mn} = Y_{mn} (\theta_m - \theta_n) \quad (\text{A.3})$$

which for the three node system gives

$$\begin{bmatrix} F_{12} \\ F_{13} \\ F_{23} \end{bmatrix} = \begin{bmatrix} Y_{12} & -Y_{12} & 0 \\ Y_{13} & 0 & -Y_{13} \\ 0 & Y_{23} & -Y_{23} \end{bmatrix} \begin{bmatrix} \theta_1 \\ \theta_2 \\ \theta_3 \end{bmatrix} \quad (\text{A.4})$$

(A.2) and (A.4) can be rewritten and combined as

$$P = CA\theta = B\theta \quad (\text{A.5})$$

$$\begin{bmatrix} P_1 \\ P_2 \\ P_3 \end{bmatrix} = \underbrace{\begin{bmatrix} 1 & 1 & 0 \\ -1 & 0 & 1 \\ 0 & -1 & -1 \end{bmatrix}}_B \begin{bmatrix} Y_{12} & -Y_{12} & 0 \\ Y_{13} & 0 & -Y_{13} \\ 0 & Y_{23} & -Y_{23} \end{bmatrix} \begin{bmatrix} \theta_1 \\ \theta_2 \\ \theta_3 \end{bmatrix} \quad (\text{A.6})$$

Node 1 is selected as reference node, i.e. $\theta_1 = 0$. The element in B , corresponding to the reference node can then be removed which results in

$$\theta' = B'^{-1}P' \quad (\text{A.7})$$

$$B'^{-1} = \begin{bmatrix} B_{22} & B_{23} \\ B_{32} & B_{33} \end{bmatrix}^{-1} \quad (\text{A.8})$$

The matrix B^* is formed by the elements from B'^{-1} and with zeros in the elements corresponding to the reference node.

$$B^* = \begin{bmatrix} 0 & 0 & 0 \\ 0 & B'_{11} & B'_{12} \\ 0 & B'_{21} & B'_{22} \end{bmatrix} \quad (\text{A.9})$$

The distribution matrix M is then calculated as

$$M = AB^* \quad (\text{A.10})$$

$$\begin{bmatrix} M_{11} & M_{12} & M_{13} \\ M_{21} & M_{22} & M_{23} \\ M_{31} & M_{32} & M_{33} \end{bmatrix} = \begin{bmatrix} Y_{12} & -Y_{12} & 0 \\ Y_{13} & 0 & -Y_{13} \\ 0 & Y_{23} & -Y_{23} \end{bmatrix} \begin{bmatrix} 0 & 0 & 0 \\ 0 & B'_{11} & B'_{12} \\ 0 & B'_{21} & B'_{22} \end{bmatrix} \quad (\text{A.11})$$