

Modelling of Heat Recovery Equipment



Magnus Arnell & Ramesh Saagi

Division of Industrial Electrical Engineering and Automation
Faculty of Engineering, Lund University



LTH
FACULTY OF
ENGINEERING

Modelling of Heat Recovery Equipment

Magnus Arnell

Ramesh Saagi

Division of Industrial Electrical Engineering and Automation
Department of Biomedical Engineering
Lund University

Contents

Introduction	3
Background.....	3
Model Description	4
Heat Exchanger Model	4
Heat Pump Model.....	5
Model Implementation and Simulation Results	6
Simulation of Heat Exchanger Application	6
Simulation of Heat Pump Application	7
Generic Heat Pump Model for System-Wide Model Application	7
Acknowledgements	7

Nomenclature

ASM	IWA Activated Sludge Models No. 1 to 3	
C_{\min}	Minimum heat capacity	[kW/K]
$c_{p,i}$	Heat capacity – index i denotes cold or hot media	[kJ/kg/K]
COP	Coefficient of performance (for heat pumps)	
DHW	Domestic hot water	
ε	Effectiveness of the heat exchanger	[-]
E_{cond}	Energy transferred in heat pump condenser	[kW]
HEX	Heat exchanger	
HP	Heat pump	
\dot{m}_i	Mass transfer rate – index i denotes cold or hot media	[kg/s]
P	Power input for heat pumps	[kW]
$T_{i,j}$	Temperature for stream – index i indicates cold or hot media, index j denotes in and out temperature	[K]
Q_i	Flow for stream index i	[m ³ /d]
q	Actual heat transfer in heat exchanger	[kW]
WW	Wastewater	
WWHR	Wastewater heat recovery	
WWTP	Wastewater treatment plant	

Introduction

This is an internal report in the research project Sustainability Analysis of Wastewater (WW) Heat Recovery (WWHR) – Hållbarhetsanalys av värmeåtervinning ur avloppsvatten (HÅVA), in Swedish – coordinated by the Division of Industrial Electrical Engineering and Automation at Lund University, Lund, Sweden. Key partners in the project are RISE Research Institutes of Sweden, the wastewater utilities VA Syd (Malmö), Tekniska Verken (Linköping), Käppalaförbundet (Stockholm), and the real estate company Stångåstaden (Linköping).

In the project, a system-wide sustainability analysis is performed using mechanistic energy balance and process models. The model includes components to describe the origin of domestic wastewater in buildings through WWHR units, heat transfer processes in the sewers and the impact of temperature changes on the wastewater treatment plant (WWTP). The literature review on WWHR identified wastewater characteristics as a key variable for the model (Arnell *et al.*, 2017). This document contains a description of models for wastewater heat recovery equipment, i.e. heat exchangers (HEXs) and heat pumps (HPs).

Background

Wastewater heat recovery systems are mainly based on exchanging heat from outgoing wastewater for pre-heating cold water and thereby reducing the energy required for the heating system to produce hot water. The technology can be implemented in different positions in the wastewater system. Principally, there are four different positions, Figure 1:

1. At component level, i.e. household appliances, showers etc. with internal heat (and possibly even water) recycling;
2. At property level, i.e. heat is recovered from collected wastewater (or separated greywater) from the property and recycled for pre-heating tap water or heating/cooling the building;
3. At precinct level, i.e. in the sewer network where heat can be recovered by, for example, heat pumps;
4. At system level, i.e. at the wastewater treatment plant (WWTP) where heat pumps are used to recover heat from the treated effluent.

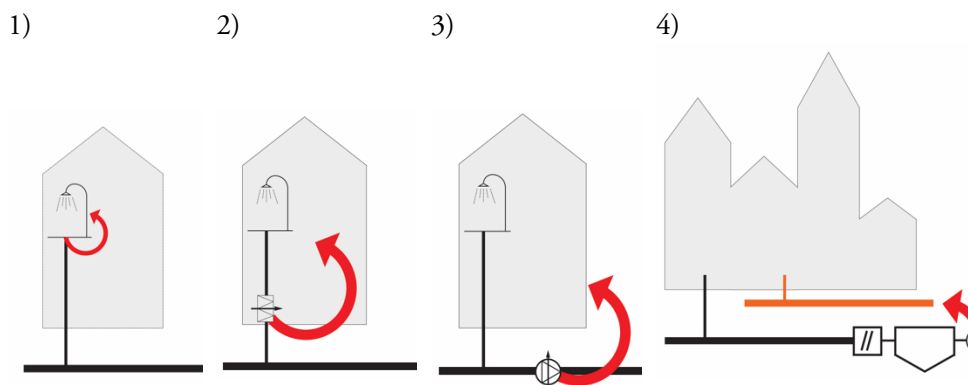

Figure 1. Positions (1 to 4) for implementation of wastewater heat recovery. 1) appliance level; 2) property level; 3) precinct level; and 4) system level.

Depending on the position, different types of equipment are applicable for WWHR. Generally, simpler passive equipment, such as heat exchangers, are used the further

upstream the installation is made (Jonsson *et al.*, 2020). As the flows and potential energy recovery increases downstream, more advanced equipment is used, mainly different kinds of heat pumps (Hepbasli *et al.*, 2014), even if examples of the opposite exist (Cecconet *et al.*, 2020). The simplest heat exchangers are used in showers, etc. and might consist of a coiled hose in the shower floor transferring some effluent heat to the cold tap water provided to the shower (Wong *et al.*, 2010). At building level, a large variety of HEXs are used, ranging from copper coils around sewer pipes (see cover illustration) to industrial type HEXs. For heat pump installations, different standard and custom-built equipment are used. However, each installation is typically case specific depending on WW characteristics and flow, use of the recovered heat, etc.

Model Description

Heat Exchanger Model

The heat exchangers used in this application are assumed to be of counter-current flow design, see Figure 2. Based on standard equations, the heat exchanger is modelled as follows (Geankoplis, 1993):

$$q = \varepsilon \cdot C_{\min}(T_{h,in} - T_{c,in}) \quad (1)$$

$$C_{\min} = \min_{i=c,h}(\dot{m} \cdot c_p)_i \quad (2)$$

$$T_{h,out} = T_{h,in} - \frac{q}{(\dot{m} \cdot c_p)_h} \quad (3)$$

$$T_{c,out} = T_{c,in} + \frac{q}{(\dot{m} \cdot c_p)_c} \quad (4)$$

where,

q is the actual heat transfer [kW];

ε is the effectiveness of the HEX [-];

C_{\min} is the minimum heat capacity [kW/K];

$T_{i,j}$ is the temperature – index i indicates cold or hot media, index j denotes input or output temperature [K];

\dot{m}_i is the mass transfer rate – index i denotes cold or hot media [kg/s]; and

$c_{p,i}$ is the heat capacity – index i denote cold or hot media [kJ/kg/K].

The primary output variables are $T_{c,out}$ and $T_{h,out}$ which in the normal case are the effluent temperatures of the heated water and the wastewater from the HEX. The effectiveness, ε , is a function of the area, A , and overall heat transfer coefficient, U , for the specific heat exchanger and is provided as diagrams or as data by the supplier. If fouling occurs this should be compensated for in the heat transfer coefficient, U . In practice, ε is measured in actual conditions (flow rate and temperature), thus A and U are not used in the model directly.

The equations 1 to 4 have been implemented in the Matlab / Simulink platform (Matlab 9.3, The Mathworks Inc., Natwick, MA, USA, 2017).

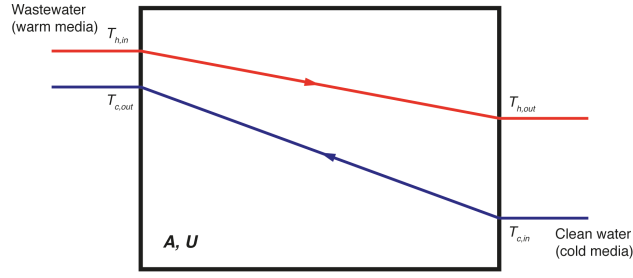

Figure 2. Principal illustration of counter-current flow heat exchanger.

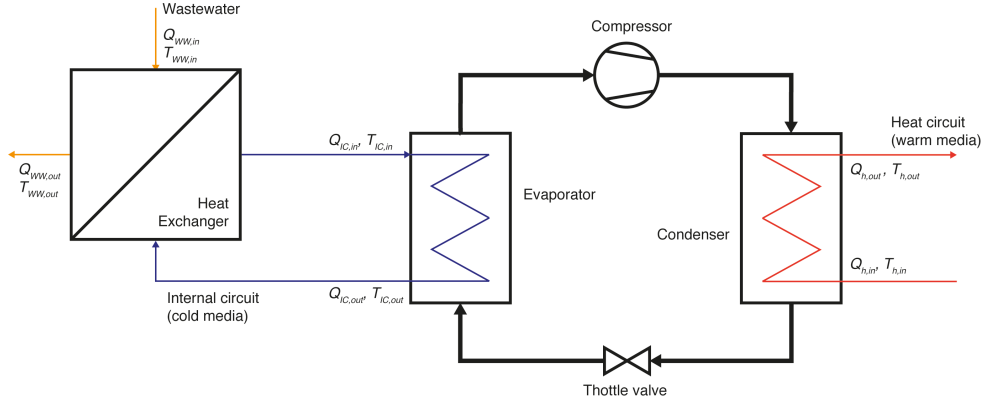

Figure 3. Principal illustration of heat pump for wastewater application.

Heat Pump Model

Heat pump installations for wastewater applications may differ depending on position of use and case specific designs. In many cases – e.g. all cases with untreated wastewater as heat source – the heat pump is protected by a heat exchanger. In practice, that means that the wastewater goes through a heat exchanger transferring energy to an internal brine media instead of being fed to the evaporator directly, see Figure 3.

The heat pump is modelled using the following equations (Geankoplis, 1993):

$$E_{\text{cond}} = -P \cdot \text{COP} \quad (5)$$

$$T_{c,\text{out}} = T_{c,\text{in}} - \frac{|E_{\text{cond}}| - P}{(\dot{m} \cdot c_p)_c} \quad (6)$$

$$T_{h,\text{out}} = T_{h,\text{in}} - \frac{E_{\text{cond}}}{(\dot{m} \cdot c_p)_h} \quad (7)$$

where:

- E_{cond} is the energy transferred in the condenser [kW];
- P is the electrical power input to the heat pump [kW]; and
- COP is the Coefficient of Performance for the heat pump [-].

This means that the system is determined by the influent flow and temperatures, the power input and the COP factor of the HP. In the case of a HEX combined with the HP as illustrated in Figure 3, a separate HEX model, Equations (1) to (4), is used together with the HP model.

Model Implementation and Simulation Results

Simulation of Heat Exchanger Application

Assuming installation of a HEX in Pos. 2 in a 35-apartment building (74 persons) with an ε of 0.30, the potential heat recovery and resulting variables can be simulated in steady state. 23.8 kWh/d can be recovered when preheating tap water for domestic hot water (DHW) production. The resulting flow rate and temperature are shown in Table 1.

Table 1. Wastewater temperature when simulating steady state heat recovery with heat exchanger.

	T_{in} [°C]	T_{out} [°C]	Q [m ³ /d]
Wastewater	23.6	21.6	10.2
Tap water to hot water supply	7.0	12.0	4.1

Given that the flow rate and temperature are dynamic variables in the system-wide BSM model, the HEX model will provide dynamic outputs. A year-long dynamic profile of domestic wastewater for 1 000 persons was generated using the WW generation model (Wärff, 2020; Wärff *et al.*, 2020) with a tap water temperature profile showing strong seasonal variations. This influent was run through the HEX model assuming an ε of 0.30. Profiles for the resulting WW temperature, recovered heat and heat demand for DHW are shown in Figure 4.

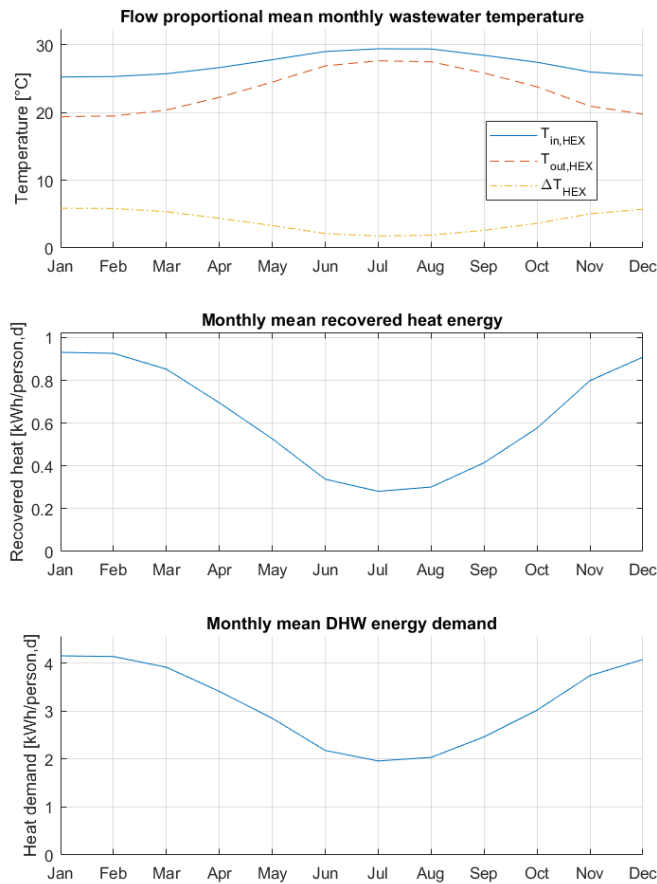

Figure 4. Wastewater temperature (top) for dynamic simulation of heat recovery with heat exchanger. Recovered heat energy (middle) and total energy requirement for domestic hot water (bottom).

Simulation of Heat Pump Application

A steady state simulation of an in-sewer (Pos. 3) heat pump installation was performed. The case featured a HEX transferring heat from WW to a brine media, which is fed to the evaporator of the HP heating water for district heating (low temperature district heating system). The case is illustrated in Figure 5. The ϵ of the HEX was assumed as 0.51, the COP of the HP as 5.9 and the power input required was 180 kW. The Simulated temperatures and flow rate are presented in Table 2.

Table 2. Wastewater temperature when simulating steady state heat recovery with heat pump.

	T_{in} [°C]	T_{out} [°C]	Q [m ³ /d]
Wastewater	18	12.5	3 283
Internal circuit (brine)	9.2	0.02	2 073
District heating water	30	35.0	4 406

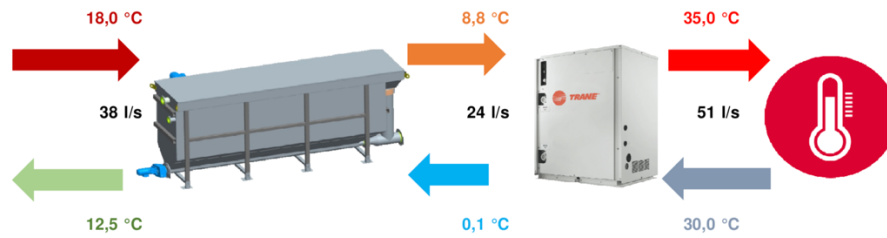

Figure 5. Case study of in-sewer installation of HP.

The simulated heat pump has good agreement with the designed one in the case study. Similar to the HEX simulations, using a dynamic influent profile will make the model produce dynamic outputs.

Generic Heat Pump Model for System-Wide Model Application

When designing heat pump installations many factors impact the performance in an intricate manner. Usually, the available heat requirement (heat sink) is limiting for the size but also temperature and flow rate on the evaporator side, leaving the condenser performance as a result. However, while HP installations are highly case specific (high degree of freedom), a generic approach was developed for the city-wide simulations in the project case studies to ensure that the simulation results are comparable. The standard design for heat pump installation (Figure 5 and Table 2) is scaled for the different locations based on the incoming wastewater flow rate (Table 2). Additionally, a feedback controller (PI control) is designed to ensure that the outgoing condenser flow always attains the desired temperature. The incoming condenser flow rate ($Q_{h,in}$) is manipulated (depending on the available heat content in the wastewater) to attain a fixed output temperature ($T_{h,out}$). The flow rate of the internal coolant ($Q_{i,c,in}$) is fixed. The power input (P) is also limited to a maximum value so that the coolant does not reach temperatures lower than 0 °C.

Acknowledgements

The project is financed by The Swedish Research Council Formas (942-2016-80), The Swedish Water and Wastewater Association (SVU 16-106) and the three water utilities Tekniska Verken (Linköping), Käppalaförbundet (Stockholm) and VA Syd (Malmö)/Sweden Water Research.

References

- Arnell M., Lundin E. and Jeppsson U. (2017). *Sustainability analysis for wastewater heat recovery – Literature review*. Report TEIE-7267, Division of Industrial Electrical Engineering and Automation, Lund University, Lund, Sweden.
- Cecconet D., Racek J., Callegari A. and Hlavinek P. (2020). Energy recovery from wastewater: A study on heating and cooling of a multipurpose building with sewage-reclaimed heat energy. *Sustainability* 12(116), 1-11.
- Geankoplis C. J. (1993). *Transport Processes and Unit Operations*. P T R Prentice-Hall Inc., Engelwood Cliffs, NJ, USA.
- Hepbasli A., Biyik E., Ekren O., Gunerhan H. and Araz M. (2014). A key review of wastewater source heat pump (WWSHP) systems. *Energy Conversion and Management* 88, 700-722.
- Jonsson R., Sundén T., Bengtsson L. and Kristoffersson J. (2020). *Värmeåtervinningssystem för spillvatten i flerbostadshus [Systems for heat recovery from wastewater in multi-family houses (in Swedish)]*, Sustainable Innovation AB, Stockholm, Sweden.
- Wärff C. (2020). *Household wastewater generation model*. Report LUTEDX/(TEIE-7279)/1-29/(2020), Division of Industrial Electrical Engineering and Automation, Lund University, Lund, Sweden.
- Wärff C., Arnell M., Jeppsson U. and Sehlen R. (2020). Modelling heat recovery potential from household wastewater. *Water Science and Technology* 81(8), 1597-1605.
- Wong L. T., Mui K. W. and Guan Y. (2010). Shower water heat recovery in high-rise residential buildings of Hong Kong. *Applied Energy* 87(2), 703-709.